



**Project Implementation Unit (PIU)  
Khyber Pakhtunkhwa Rural Investment and Institutional  
Support Project (KP-RIISP)  
Public Health Engineering Department (PHED)  
Government of Khyber Pakhtunkhwa (GOKP)**

**PROCUREMENT OF SMALL WORKS  
REHABILITATION & SOLARIZATION OF  
EXISTING DRINKING WATER SUPPLY  
SCHEMES, DISTRICT KHYBER  
RFB No. KH-SW-R-01**

**TECHNICAL SPECIFICATIONS**

**May 2026**

## Table of Contents

<b>PART-A. GENERAL .....</b>	<b>5</b>
1.1. THE PROJECT .....	6
1.2. PURPOSE AND LOCATION OF THE WORKS .....	6
1.3. DESCRIPTION OF THE WORKS .....	6
1.4. STANDARD SPECIFICATIONS .....	6
1.5. DRAWINGS.....	6
1.6. RECORD DRAWINGS.....	6
1.7. MATERIALS AND SUPPLIERS OF MATERIALS .....	6
1.8. PROGRAMME .....	7
1.9. NOTICE OF OPERATIONS.....	7
1.10. TEMPORARY WORKS .....	7
1.11. WATER AND ELECTRICITY SUPPLY.....	8
1.12. DISPOSAL OF WATER .....	8
1.13. CONTRACTOR'S FACILITIES .....	8
1.14. LATRINES .....	8
1.15. MEETINGS AND REPORTS.....	8
1.16. CONTRACT SIGNBOARD .....	8
1.17. LEVEL DATUM .....	9
1.18. MAINTENANCE OF EXISTING ACCESS TRACK DURING THE WORKS .....	9
1.19. EXISTING INSTALLATIONS .....	9
1.20. UNITS OF MEASUREMENT .....	10
1.21. LANGUAGES .....	10
1.22. ADVERTISING .....	10
1.23. SITE INVESTIGATION RECORDS .....	10
1.24. SAFETY AND ENVIRONMENTAL REGULATIONS ON SITE.....	10
1.25. OTHER WORKS AND SERVICES.....	10
1.26. COSTS .....	10
2. THE SITE .....	11
2.1. LOCATIONS.....	11
2.2. AREAS OUTSIDE THE SITE .....	11
2.3. ACCESS TO SITE.....	11
2.4. CLEARANCE AND REINSTATEMENT OF SITE.....	11
2.5. CONDITION OF SITE.....	12
2.6. LAYOUT .....	12
2.7. SITE RECORDS .....	12
2.8. PERMITS.....	12
2.9. PROTECTION OF WORKS AGAINST FLOODING.....	12
2.10. SUBSOIL INVESTIGATIONS .....	13
2.11. COSTS .....	13
2.12. SURVEY EQUIPMENT.....	13

2.13.	PLANT, EQUIPMENT AND TOOLS.....	13
2.14.	STORAGE & HANDLING FACILITIES .....	13
2.15.	TEST LABORATORY TESTING AND TESTING REPORT .....	14
2.16.	PROTECTION OF THE WORKS .....	14
2.17.	DEFINITIONS.....	14
2.18.	ABBREVIATIONS .....	14
3.	MATERIALS AND WORKMANSHIP.....	16
3.1.	STANDARD SPECIFICATIONS.....	16
3.2.	SUPPLIERS OF MATERIALS .....	16
3.3.	NATURAL MATERIALS .....	16
3.4.	SAMPLING.....	16
3.5.	LABORATORY FACILITIES.....	17
3.6.	COSTS .....	18
<b>PART-B TUBE WELL .....</b>		<b>19</b>
4.	CONSTRUCTION OF TUBE-WELLS.....	20
4.1.	SCOPE.....	20
4.2.	DESCRIPTION.....	20
4.3.	CONTRACT DRAWINGS .....	20
4.4.	SIZE OF TUBEWELL .....	21
4.5.	BILL OF QUANTITIES.....	21
4.6.	STANDARDS .....	21
4.7.	CONSTRUCTION EQUIPMENT AND MATERIAL .....	21
4.8.	CLEAN UP .....	22
5.	DRILLING OF BOREHOLE .....	23
5.1.	SCOPE OF WORK.....	23
5.2.	DRILLING OPERATION.....	23
5.3.	DRILLING .....	23
5.4.	DATA AND RECORDS.....	24
5.5.	MEASUREMENT AND PAYMENT.....	24
6.	TUBEWELL CONSTRUCTION.....	26
6.1.	SCOPE OF WORK.....	26
6.2.	CASINGS.....	26
6.3.	FIBRE GLASS STRAINER & BLIND PIPE .....	26
6.4.	FABRICATION.....	26
6.5.	GROUTING .....	28
6.6.	DEVELOPMENT AND TESTING.....	29
6.7.	SEALING .....	34
6.8.	MEASUREMENT AND PAYMENT.....	34
7.	HYPO-CHLORINATOR .....	35
7.1.	DESCRIPTION .....	35
7.2.	AUTOMATIC MECHANICAL DIAPHRAGM DOZING PUMP (HYPO-CHLORINATOR) .....	35
7.3.	DOZING TANK.....	37
7.4.	SODIUM HYPOCHLORITE .....	39
8.	WATER TESTING.....	41
8.1.	SCOPE OF WORK.....	41
8.2.	COLLECTION OF WATER SAMPLES.....	41
8.3.	TRANSPORTATION AND STORAGE OF SAMPLES.....	41

---

8.4.	LABORATORY EXAMINATION .....	42
8.5.	RECORD & DATA .....	42
8.6.	MEASUREMENT AND PAYMENT.....	42
9.	CONSTRUCTION OF PUMP HOUSE .....	43
9.1.	SCOPE OF WORK.....	43
9.2.	MATERIALS AND CONSTRUCTION REQUIREMENTS .....	43
9.3.	MEASUREMENT AND PAYMENT.....	43
10.	ELECTRICAL & MISC. WORKS.....	44
10.1.	SCOPE OF WORK.....	44
10.2.	ELECTRICAL WORKS .....	44
10.3.	POWER TRANSFORMER .....	49
10.4.	MEASUREMENT AND PAYMENT.....	51
<b>PART-C SOLAR WORKS .....</b>		<b>52</b>
11.	SOLAR PANELS .....	53
11.1.	CABLES, WIRING AND PROTECTION DEVICES: .....	54
11.2.	PANEL MOUNTING & STRUCTURE: .....	56
11.3.	EARTHING/ GROUNDING: .....	58
11.4.	BATTERIES:.....	58

## **PART-A. GENERAL**

## 1.1. THE PROJECT

Design Review and Construction Supervision for Water Supply, Sewerage, Drainage and Waste Water Treatment Project in Newly Merged Districts of Khyber Pakhtunkhwa under Khyber Pakhtunkhwa Rural Investment and Institutional Support Project

## 1.2. PURPOSE AND LOCATION OF THE WORKS

The purpose of the proposed project is to expand access to and coverage of citizen-centric public services, to invest in the provision of critical public services in priority sectors, with a focus on poor and vulnerable households. The targeted project area will cover eight (8) newly merged districts (NMD) and six (6) Tribal Sub-Divisions (TSDs).

## 1.3. DESCRIPTION OF THE WORKS

This project relates to (a) Design review and construction supervision of the drinking water supply schemes as per the mode of source and power i.e. Gravity, Solar and Electric based. (b) Design review and construction supervision of sanitation schemes including Urban and Rural areas having components of drainage, sewerage and wastewater treatment. (c) rehabilitation of existing schemes including its designing and subsequently its construction supervision.

## 1.4. STANDARD SPECIFICATIONS

Plant, materials and workmanship shall comply with the requirements of relevant National and International Standards and Codes of Practice current at the time of bid.

The Contractor shall supply two copies of each ASTM, AASHTO, ACI, BS, EN and BSCP and other approved national or international standards which refer the specifications and other standards which apply to materials which are being supplied and workmanship which is being executed on the Works. One copy shall be available to the Engineer and other copy shall be kept by the Contractor on the site.

All materials and workmanship not covered by a ASTM, AASHTO, BS or BSCP or other approved standards shall be used in first class work and suitable for the climate in the area where the works are to be executed, for which Engineer's decision is a binding.

## 1.5. DRAWINGS

Drawings which form part of the Contract are attached in Volume III.

## 1.6. RECORD DRAWINGS

Within twenty-eight days of the issue of Certificate of Completion, the CONTRACTOR shall provide 6 copies and one reproducible of all drawings amended to comply with the works as built. These drawings shall include:

- General arrangement drawing of the structures, pipelines and Permanent Works
- Longitudinal sections of water lines and chambers shall be as shown on the Issued Drawings or as agreed by the consultant.

## 1.7. MATERIALS AND SUPPLIERS OF MATERIALS

Before ordering materials of any description intended for the Permanent Works, the contractor shall submit for the approval of the consultant the names of the makers or suppliers proposed, a specification of the materials and details of their place of manufacture. The contractor may be required to supply to the consultant for his retention, a copy of each order placed.

## 1.8. PROGRAMME

Before commencing the Works the contractor shall submit to the consultant for his approval a programme showing the order in which he proposes to carry out the Works. The programme shall be in the form of a bar chart, or any other form as may be agreed by the consultant, and shall clearly indicate the following:

- a. the sequence of each activity, the proposed start and completion dates of each activity, the rate of progress and the cumulative quantity or percentage of work expected to be achieved on each activity by the end of each month;
- b. the time allocated for work by others, including those of the client and by utility undertakings;

The programme shall also include details of the following:

- a. A statement giving the numbers and categories of supervisory and technical staff and skilled and unskilled workers to be employed on the Works.
- b. A list and type details of major Constructional Plan (including vehicles) which the contractor proposes to employ on the Works.
- c. Details of the contractor's methods of working for all operations.
- d. A statement giving the proposals for location or locations and sizes of base camps, accommodation, offices, workshops and stores.
- e. Details of the programme for the Works from the date of receipt of the consultant order to commence the Works including a complete resources allocation showing the number of units and allotted times for each unit of Constructional Plan, materials and labour allocated to each part of the works.

## 1.9. NOTICE OF OPERATIONS

The contractor shall give full and complete written notice of all important operations to the consultant sufficiently in advance to enable the consultant to make such arrangements as he may consider necessary for inspection or for any other purpose. The contractor shall not commence any important operation without the written approval of the consultant.

The consultant's Site supervision staff shall be working 8 hours per day, Monday to Saturday. Expense incurred due to operations beyond above stated time frame which requires consultant's staff supervision, shall be borne by the contractor.

## 1.10. TEMPORARY WORKS

Not less than fourteen days before commencing any portion of the Works, the contractor shall, if ordered, submit to the consultant for his approval complete drawings and calculations for all Temporary Works the contractor may be proposing for the construction of that part of the Works.

Notwithstanding approval by the consultant of any design for the Temporary Works, the contractor shall be entirely responsible for their efficiency, security and maintenance and for all obligations and risks in regard to such Temporary Works specified or implied in the Contract.

### **1.11. WATER AND ELECTRICITY SUPPLY**

The contractor shall at his own cost make arrangements for the supply of water and electricity for the purposes of the Works.

### **1.12. DISPOSAL OF WATER**

Water and wastewater derived from the construction, testing and completion of the Works shall be disposed of clear of the Site to the satisfaction of the consultant so as to cause no damage or complaint.

### **1.13. CONTRACTOR'S FACILITIES**

The contractor shall provide all site facilities including offices with telephone, workshops, stores, accommodation, washing, latrines etc. necessary for use by his own staff.

The contractor shall be responsible for making all arrangements for drainage from his site facilities and shall be responsible for payment of all charges in connection therewith. Arrangements for the supply of electricity, water and gas shall be the responsibility of the contractor.

Works Areas for the Contract in addition to those defined as Site of the Works shall be agreed with the consultant.

### **1.14. LATRINES**

Throughout the period of construction of the Works the contractor shall provide, maintain and cleanse suitable and sufficient latrines for use by his employees; he shall ensure that his employees do not foul the Site but make proper use of the latrines. Where practicable the latrines shall be connected to the nearest sewer, or if this is not practicable the contractor shall provide an adequately sized septic tank and soak away.

### **1.15. MEETINGS AND REPORTS**

Representatives of the contractor, approved by the consultant, shall attend monthly progress meetings on Site or at the offices of the Client/Consultant at any other place. In addition, approved representatives of the contractor shall attend further meetings in cases of emergencies or for other reasons when called upon by the Client/Consultant.

The contractor shall submit to the consultant each month a report on his progress on the performance of the Contract. The report shall include a copy of the approved programme with the current progress for each activity shown. No separate payment shall be made for this item.

### **1.16. CONTRACT SIGNBOARD**

The contractor shall supply and erect one or more contract signboards at locations agreed by the consultant. The signboards shall be of substantial construction to the approval of the consultant and the lettering, in both English and Urdu shall be black on a yellow fluorescent background.

The layout and dimensions of the signboard shall be with the approval of the consultant's Representative.

### **1.17. LEVEL DATUM**

All levels stated shall be related to bench-marks locations with its elevation datum at mean sea level.

### **1.18. MAINTENANCE OF EXISTING ACCESS TRACK DURING THE WORKS**

On commencement of the Contract, the contractor shall be solely responsible for the maintenance of the existing access roads within the Site. This responsibility shall continue until the contract completion date, or until such earlier date as the consultant may advise the contractor in writing. In preparing his rate for maintenance of these access roads, the contractor shall take into account that the access roads under his maintenance control will also be used by the CLIENT's and his staffs vehicles and also those of other contractor. Such maintenance work shall include general up keeping, and any necessary repairs to damaged road surfaces, pavement, drainage, associated slopes, etc (whether caused by the contractor's activities or not) to a standard no worse than the original condition. During the carrying out of such maintenance work, the contractor shall make arrangements to maintain through passage for the CLIENT's and his, staff's vehicles and also those of other contractor over these access roads, which may comprise temporary diversions all to the approval and satisfaction of the consultant.

The contractor shall not run tracked or unsprung vehicles on surfaced roads without the express approval of the consultant who may require that planking or some other protective material be used to protect the road surface.

### **1.19. EXISTING INSTALLATIONS**

The contractor shall execute the Works in such a manner as to avoid interruption and interference with the operation of the existing water and sewerage conveyance system, treatment works, pumping stations and distribution systems and to minimize disturbance to the existing staff quarters and mosque adjacent to the Site. Access to the existing facilities shall be maintained, to the satisfaction of the consultant, at all times.

The contractor shall apply to the consultant in writing at least 28 days before starting any work which involves interference with existing structures, equipment, etc., or otherwise interfere with or interrupt the CLIENT's normal operation of the existing conveyance system, pumping and treatment works, and distribution system. The contractor shall not execute such work until he has received permission to proceed, in writing from the consultant.

The contractor shall ensure that no earth, debris or rock is deposited on existing conduits, structures, public or private roads or rights of way as a result of the Works and all vehicles leaving the Site shall be cleaned accordingly.

The contractor shall be responsible for the safety and security of existing services encountered during the course of execution of works and any damage to existing installation and services due to contractor's operations shall be made good at his risk and cost. The contractor shall gather the information of all services require protection and relocations, falls within the area of works, from SSGC, PESCO, PTCL, TMA and any other agencies. The contractor shall strictly comply with the safety and precautions requirements as deemed necessary by the owner of the services.

## **1.20. UNITS OF MEASUREMENT**

All designs, drainage, specifications and manuals shall use either FPS, MKS or SI (kg m s) units, but any unit system used shall be consistent for the project and all measurements, dimensions and performance data shall be quoted in those units.

## **1.21. LANGUAGES**

All drawings, instructions, signs, notices, name-plates etc. for use in the operation and maintenance of the completed works shall be in English.

Warning signs shall be in Urdu and English.

## **1.22. ADVERTISING**

The contractor shall not use any part of the Site for any form of advertising without the prior written approval of the ENGINEER.

## **1.23. SITE INVESTIGATION RECORDS**

The site investigation if deemed necessary by the consultant, during the execution of the work shall be carried out by the contractor at his own cost.

Before commencement of work at site the contractor shall carry out the trial pits up to the required formation level to locate any existing underground services and utility lines.

## **1.24. SAFETY AND ENVIRONMENTAL REGULATIONS ON SITE**

The contractor shall comply with all statutory and other regulations concerning the safety of his site staff, operatives, staff of the client and consultant and members of the public and protection of Environment, as a result of his operations. He shall obtain copies of all the relevant regulations, and shall make them available for inspection by the consultant.

## **1.25. OTHER WORKS AND SERVICES**

For all other works and services specified in the Specifications or shown on Drawings and for which there is no separate item in the Bill of Quantities, no payment shall be made directly and the cost thereof shall be deemed to be included in the unit rates of other items of BOQ, except as decided by the Engineer.

## **1.26. COSTS**

The costs for complying with this section of specification shall not be paid separately and shall be included in the contractor's rates and prices of the Bill of Quantities.

## **2. THE SITE**

### **2.1. LOCATIONS**

The extent of the site is defined in Bidding Documents. The contractor shall not use the site for any purpose not required by the Contract.

### **2.2. AREAS OUTSIDE THE SITE**

For the contractor making use of any special or temporary way leave or additional accommodation acquired by him or any tip for the disposal of surplus materials, he shall obtain the written consent of the owner, occupier or authority having charge of the land in which such way leave, accommodation or tip is situated and shall make a record agreed by the owner, occupier or authority as aforesaid of the condition of the surface of that land before entering thereon.

The contractor shall permit the Client and the consultant and any person authorized by the Client or the consultant access for the purposes of the Contract to any such special or temporary way leave or additional accommodation.

In the event of the contractor making use of any special or temporary wayleave or additional accommodation made available to him by the Client for the purpose of the Contract, the land in which such way leave or accommodation is situated shall be deemed to be part of the Site as defined in Clause 2.1 hereof.

For the purposes of this Clause, 'accommodation' shall be deemed to include housing, offices, workshops, warehouses, storage areas and disposal areas.

### **2.3. ACCESS TO SITE**

The contractor shall where necessary, provide access to and through the site to adjacent properties as well as to other agencies/contractor who might be executing any development work for PHED or for any other agencies and coordinate his work with these agencies / contractors.

Before the commencement of any part of the Works, the contractor shall make temporary access tracks including temporary diversions, approach roads, temporary roads in side river for movement of vehicles, transporting Pipe lines and other Construction material during execution of the work with approval of the consultant. The Contractor shall maintain such access tracks in a condition suitable for the safe and easy passage of plant, vehicles and pedestrians required for the purpose of the Contract.

The Contractor shall make a record to be agreed by the consultant of the condition of the surfaces of any private lands or of any public cultivated or maintained lands over which access to the Site lies before any work is commenced to make them suitable for access and he shall keep such surfaces in a reasonable state of cleanliness and repair during the execution of the Works. On the termination of The Contractor's use of such access he shall restore the surfaces to a condition at least equal to that existing before his first entry on them.

### **2.4. CLEARANCE AND REINSTATEMENT OF SITE**

The Contractor shall clear the Site of all vegetation, trees, hutments, obstructions etc. to the extent required by the consultant for checking the setting out. The Contractor shall also ensure that the parts of the Site to be occupied by the Permanent Works are clear and maintain the remainder of the Site as may be required for access and Temporary Works areas.

The Contractor shall remove the material arising from such clearance and dispose off it in a manner and at a location, away from the site and inhabitant areas, no obstruction shall be caused to the existing traffic and adjacent properties and no excavated material shall be dumped or stock pile at site but removed directly to disposal areas identified by the Contractor, to the approval of the Consultant.

No heavy equipment/ plant whether mobile or stationery shall be allowed to come nearer than 1.5 m of the existing water and sewage conveyance structures. For this purpose, such structures and pipelines shall be protected by erecting warning fence or barricades.

The Contractor shall fill and make good with appropriate materials those cavities and losses of soil which result from clearing the parts of the Site not subsequently to be occupied by the Permanent Works.

The Contractor shall not clear the Site of any structure without the prior written permission of the consultant.

Before start of concreting work the contractor will carry out sub soil investigations to establish soil characteristics and record ground water levels. Results of the test shall be timely reported to the Engineer before execution of the project.

## **2.5. CONDITION OF SITE**

The Contractor shall maintain the Site in a neat, tidy and healthy condition for the whole of such time as he is responsible for the care of the Works.

## **2.6. LAYOUT**

The layout of works for the purposes of execution of roads, water supply, sewerage, drainage and facilities under the scope of work shall be carried out by the Contractor subject to confirmation / check by the Engineer which must be accurately as per the Drawings and instructions of the Engineer. Before commencement of construction work, the layout shall be checked and certified by the Engineer's Representative or Engineer. The measurement for payment shall not be taken for this item of the work, price shall be deemed

## **2.7. SITE RECORDS**

The Contractor shall make records of the position and extent in the excavations of every type of service, stratum and obstruction encountered during the construction of the Works.

## **2.8. PERMITS**

The Contractor shall be fully responsible for obtaining necessary permits and permissions, except those normally obtained by the PHED or consultant, prior to commencement of the Works.

## **2.9. PROTECTION OF WORKS AGAINST FLOODING**

The Contractor shall ensure the protection of all temporary and permanent works including plants, materials and equipment against flooding caused by sewage flow in river / nala as well as recurrent rains or any other reasons, during the course of execution of works. Before the commencement of works the Contractor will submit its detail work methodology, for Consultant's approval, showing manners to divert the existing flows in the river/nala away from

the work area to be acquired in orderly state. The Contractor shall maintain such flow diversions in part or as a whole till the works have been completed or covered in accordance with drawing, specifications or as directed by the consultant. The cost of complying with this section is deemed to be included in other items of BOQ, unless expressly specified otherwise.

## 2.10. SUBSOIL INVESTIGATIONS

Before start of Contract Works, the contractor will carry out sub soil investigations to establish soil characteristics and record ground water levels. Results of the test shall be timely reported to the Engineer before execution of the project.

## 2.11. COSTS

The costs for complying with this section of specification shall not be paid separately and shall be deemed to be included in the Contractor's rates and prices of the Bill of Quantities.

## 2.12. SURVEY EQUIPMENT

The Contractor with the approval of the Engineer shall provide survey equipment for the Engineer's Representative and his staff which shall be of the number, type and quality (or equivalent) as listed in Table 1.1.

**Table 1 - List of Survey Equipment**

Sr. No.	Equipment	Quantity
1.	Total Station complete with Standard Accessories model SOKKIA SET 2010 or Equivalent	1-No.
2.	Single Tilting Range Pole Prism Complete Set Model SOKKIA KPS 11 PT or Equivalent	1-Set
3.	Single Tilting Prism W / Coaxial Target Complete Model SOKKIA KPS 12 or Equivalent Model B20	1-Set
4.	Automatic Levels, with Standard Aluminium Tripod	2-Nos.
5.	Steel Measuring Tapes 50m and 20m long	2-Each
6.	Steel Measuring Tapes 3m long	6-Nos.
7.	Leveling Staff (4m)	2-Nos.
8.	Ranging Rods	as required
9.	All Miscellaneous Tools, Equipment and Materials required in Surveying	as required

The cost of said survey equipment shall be deemed included in other items of works; as such no separate payment shall be made. All surveying equipment shall be new and maintained in perfect working condition throughout the contract period and replaced by the Contractor in case of damage or loss under the terms and condition of the agreement.

## 2.13. PLANT, EQUIPMENT AND TOOLS

The Contractor shall provide at his cost modern plant, equipment and tools, adequate and befitting to the nature, magnitude and size of this Contract, in strict compliance with the requirements of the Contract.

## 2.14. STORAGE & HANDLING FACILITIES

The Client will provide the necessary space if available with him, for constructional activities including batching plant, laboratory, workshop, storage of plant, equipment and materials and for Contractor's temporary office/camp, during the currency of the Contract. If the space is not

available with the Client then the contractor shall arrange these facilities without additional cost to the Client.

## **2.15. TEST LABORATORY TESTING AND TESTING REPORT**

Testing, except as otherwise specified herein, shall be performed by testing agency approved by the Engineer and at no extra cost to the Client. The Contractor shall bear the Cost of such Testing. The Engineer may require all or part testing to be carried out under his supervision only. The quality control testing shall be performed by the Contractor's competent personnel in accordance with a site testing and quality control program to be established by the Contractor and approved by the Engineer. The Contractor shall keep a complete record of all quality tests performed on site.

All quality control and tests shall be carried out in accordance with applicable standards and codes.

## **2.16. PROTECTION OF THE WORKS**

The Contractor shall whenever necessary cover up and protect the works from weather and damage by his own or other workmen performing subsequent operation at no extra cost to the Client including all necessary dust sheets, barriers and guard rails and clear away the same on completion.

## **2.17. DEFINITIONS**

Capitalized terms used in these specifications shall have the meanings specified in Volume-I, Condition of Contract, unless the context expressly or by necessary implication otherwise requires.

## **2.18. ABBREVIATIONS**

Whenever, in these specifications, the following abbreviations are used, the intent and meaning shall be interpreted as follows:

°C	Degree Centigrade
°F	Degree Fahrenheit
AASHTO	American Association of State Highway and Transportation Officials
ASTM	American Society for Testing and Materials
ACI	American Concrete Institute
ASIC	American Institute of Steel Construction
ASCE	American Society of Civil Engineers
AWWA	American Water Works Association
BCP	Building Code of Pakistan
BS	British Standards
BSI	British Standard Institute
CBR	California Bearing Ratio
cm	Centimeter

DIN	Deutsches Institut für Normung
EN	European Norm
HDPE	High Density Polyethylene Pipe
HP	Horse Power
ISO	International Standards Organization
JMF	Job Mix Formula
Kg	Kilogram
km	Kilometre
lb	Pound
m	Meter
mm	Millimetre
PN	Pressure Nominal
WBM	Water Bound Macadam

### **3. MATERIALS AND WORKMANSHIP**

#### **3.1. STANDARD SPECIFICATIONS**

Except where otherwise specified plant, materials and workmanship shall comply with the requirements of the relevant National Standards or American Society for Testing and Materials, British Standards and Codes of Practice (hereinafter referred to as ASTM, BS or CP current at the time of bid. Other equivalent National or International Standard Specifications may be substituted at the sole discretion of the ENGINEER or as may have been agreed in the Contract. All standards used will be the current version at the time of bidding.

The Contractor shall supply two copies of each ASTM, AASHTO, ACI, BS, EN and BSCP and other approved national or international standards which refer the specifications and other standards which apply to materials which are being supplied and workmanship which is being executed on the Works. These standards and reference works shall be supplied to the Consultant within 60 days of the Consultant's order to commence the Works. One copy shall be available to the Consultant and other copy shall be kept by the Contractor on the site.

All materials and workmanship not covered by a ASTM, AASHTO, BS or BSCP or other approved standards shall be used in first class work and suitable for the climate in the area where the works are to be executed, for which Engineer's decision is a binding.

A list of standards and other publications referred to in the Specification is given in respective sections.

#### **3.2. SUPPLIERS OF MATERIALS**

Before ordering material of any description intended for the Permanent Works, the Contractor shall submit for the approval of the ENGINEER the names of the maker or supplier proposed, a specification of the material and details of the place of origin or manufacture. If it is found necessary test regarding its compatibility with specifications be carried out at external facility. If requested by the consultant the Contractor shall supply to the consultant for his retention, a copy of any such order placed.

All materials used in the Permanent Works must be new, unless the use of old or refurbished material is expressly permitted by the Specification or the consultant.

Materials used in the Works which are, or can be, in contact with the untreated or treated water shall not contain any matter which could impair taste, odour or toxicity or otherwise be harmful to health or adversely affect the water conveyed. Approval by bodies mentioned in Clause 1.6 will generally be regarded as satisfactory evidence of suitability.

#### **3.3. NATURAL MATERIALS**

The Contractor shall make all arrangements for locating, selecting, and processing natural materials to comply with the Specification and shall submit to the consultant for approval full information regarding the proposed location well in advance of commencement of working of the material. Approval of a location shall not imply that all material in that location is approved.

#### **3.4. SAMPLING**

The Contractor shall provide the Consultant with samples of materials necessary for testing in accordance with the Contract. Unless expressly excused the Contractor shall also provide samples of all manufactured items required for the Permanent Works, or alternatively the

Contractor shall submit trade literature where the provision of samples, in the first instance, is impracticable.

All samples rejected by the Consultant shall be removed from Site. All approved samples shall be stored on Site by the Contractor for the duration of the Contract, and any materials or manufactured items subsequently delivered to Site for incorporation to the Permanent Works shall be of a quality at least equal to the approved sample.

### 3.5. LABORATORY FACILITIES

The Contractor shall, for the duration of the Contract, supply maintain and operate a materials testing laboratory at site necessary for sampling, preparing and testing materials as specified. The Contractor may also use an off-site testing laboratory to perform certain of the specified tests. Both the laboratory and the tests shall be to the approval of the Consultant, such approval shall not be given if significant delays in obtaining results are likely, or if the results may be unreliable. The Contractor shall make all the necessary arrangements and provide all transport and labour for conveying the samples to the approved laboratory, and shall ensure that any results are conveyed to the Consultant 's Representative promptly. The Consultant's approval will be withdrawn if the service proves in any way unsatisfactory.

The Contractor shall provide trained and qualified Material Engineer, technicians and skilled labour to carryout specified tests to the satisfaction of the Consultant's representative. The Material Engineer and technicians shall be approved by the Consultant. In case of unsatisfactory performance such approval will be withdrawn and the Contractor shall arrange for suitable replacements for approval by the Consultant's representative.

The Consultant and his supervisory staff shall have access to the laboratory to supervise testing and to witness verification tests ordered by the Consultant or his staff.

The Contractor shall keep records of all tests he conducts in connection with compliance with, and as required by, the Specification, and shall supply copies of the results of such tests to the Consultant's Representative as soon as practicable after each test is made.

Notwithstanding the above the Contractor shall supply, maintain and operate all the necessary apparatus for certain tests which shall be carried out within the Permanent Works or elsewhere on the Site as directed by the Consultant; these tests are as follows:

#### 3.5.1. Concrete Tests

- |     |  |                |
|-----|--|----------------|
| (a) | Slump test   | to ASTM C-143  |
| (b) | Aggregate moisture test<br>for determination of water/cement ratio | to ASTM C-566  |
| (c) | Concrete Cylinder crushing strength test                           | to ASTM C-39   |
| (d) | Elongation and flakiness of aggregate                              | to ASTM D-4791 |
| (e) | Gradation of Aggregates  | to ASTM C-136  |
| (f) | Soundness of the aggregates  | to ASTM C 88   |

The Contractor shall be responsible for making and curing test cylinders in accordance with ASTM C-31 and for measuring the temperature of atmosphere, formwork, concrete constituents and concrete itself as directed by the Consultant from time to time, and shall provide and maintain the equipment for so doing.

### 3.5.2. Soil Compaction Tests

- |     |  |                 |
|-----|--|-----------------|
| (a) | Determination of the dry density/moisture Content relationship of soil   | to AASHTO T-180 |
| (b) | Determination of the dry Density of soil   | to AASHTO T-191 |
| (c) | Sand replacement test  | to ASTM D 2974  |
| (d) | Determination of organic matter Content in soil  | to ASTM D 2974  |
| (e) | Atterberg limit tests  | to ASTM D 4318  |
| (f) | Soil gradation analysis by mechanically vibrated sieves  | to ASTM D 421   |
| (g) | Soil gradation by Hydrometer (longstem type calibrated at 20° C)   | to ASTM D 422   |
| (h) | Determination of sulphates content as SO <sub>3</sub>  | to ASTM D 2974  |
| (i) | Testing of water samples for electrical conductivity, soluble Cations and Anions, PH and dissolved solids etc. | to ASTM C 1602  |

In addition, the following equipment will also be required:

- 1 No drying oven of a type approved by the Consultant and suitable for soil testing;
- 1 set Speedy Moisture Tester with balance and soil moisture absorbent, complete set in wooden case (for soil sample, 13 grammes);
- Spare Speedy Moisture absorbent, Calcium Carbide

### 3.6. COSTS

The costs for complying with this section of specification shall not be paid separately and shall be deemed to be included in the Contractor's rates and prices of the Bill of Quantities.

## **PART-B TUBE WELL**

## **4. Construction of Tube-Wells**

### **4.1. Scope**

The work covered shall consist of well drilling, installation of components, shrouding, development and testing including all plant, labour, equipment & other miscellaneous works necessary for the satisfactory completion of the tube-well as specified and approved by The Engineer/ Engineer-in-Charge.

Before proceeding with the work, the Contractor shall submit a complete work plan for performing the work. This will include but not limited to manpower, Plant and equipment and schedule of performance for completion of work.

The Contractor shall employ at site a fulltime competent Supervision staff for overall supervision of the work.

### **4.2. DESCRIPTION**

The tube well of indicated capacity is to be drilled by direct rotary or reverse rotary method. Total depth of borehole shall vary depending upon the material encountered. An accurate drilling log of the tube well is to be made, and samples of the materials encountered through which the tube well is drilled are to be preserved and handed over to the Engineer.

Upon completion of drilling, blind and slotted tube well casing sections, of specified material, diameter and length are to be placed in the tube well, mild steel pump housing casing of required diameter and length is then to be connected to the tube well casing by means of a tapered reducer and installed in the tube well.

After installation of the pump housing and tube well casing, the tube well is to be shrouded (packed and grouted) with selected gravel of specified quality, sizes and gradation and specified cement grout after which it is to be developed and tested until it will efficiently produce clear water at a pumping rate of 50% higher than the designed capacity. After the tube well has been satisfactorily developed and tested, pump house of the specified design is to be constructed. The tube well is to be equipped with a vertical turbine pump connected to a vertical hollow shaft, electric motor. All motor control and necessary electrical equipment are to be installed, placed in operating condition and tested to demonstrate that the entire installation meets the requirements of the contract documents. A chlorinator and other equipment are to be installed with the tube well as specified.

The connection of electrical equipment to the power main shall be by others, testing of the installed equipment is however, part of this contract. Construction of facilities to convey water from the discharge pipe flange point to water main is part of this Contract.

### **4.3. CONTRACT DRAWINGS**

The Drawings covering tube well and appurtenant works show the scope of work to be performed by the Contract. The tender drawings shall not be used as a basis for placing preliminary orders for materials. The drawings issued for construction will be

drawings from which shop erection, concrete placing, formwork or other construction details shall be prepared by the Contractor.

The works shall be executed in conformity with the Drawings issued.

#### **4.4. SIZE OF TUBEWELL**

The tube well may vary in depth, therefore, minimum and maximum depth for the tube well shall not be guaranteed. The pump head, pump setting and length of housing of tube well shown on the Drawings are indicative only. The horsepower, rating of the pump motor and the motor controls are specified under applicable sections of specifications.

#### **4.5. BILL OF QUANTITIES**

The bill of quantities set forth is the approximate quantities of the works. The amount of bid for each item of bill of quantities shall be full payment for completion and maintenance of the works specified herein and elsewhere in the document and drawings.

#### **4.6. STANDARDS**

Except as otherwise provided by this specification or the Drawings and in case no specification and standards are indicated in the document, all materials, equipment fabrication and testing thereof shall conform to the latest applicable standards and specifications in accordance with the specification epilogue.

If the Contractor, at any time and for any reason wishes to deviate from the above standards, or desires to use material or equipment not covered by the said standards, he shall state the exact nature of the change, the reasons for making the change and shall submit the complete specifications of the materials and equipment for approval of the Engineer, whose decision shall be conclusive and binding on the Contract.

#### **4.7. CONSTRUCTION EQUIPMENT AND MATERIAL**

Unless otherwise specifically stated in the document, the Contractor shall furnish all necessary construction equipment and material for the construction and installation of the tube well and appurtenances. The construction equipment shall include but not be limited to drilling equipment of the Rotary or percussion type, together with all supporting and additional equipment and accessories necessary for taking samples for installing the tube well casing and pumping-housing casings, for placing gravel shrouding and cement grouting, for developing and testing the tube well, for determining the straightness and verticality for pump housing casing; for constructing the cement concrete pump pedestal and floor slab for installing the pump motor, motor controls and necessary electrical equipment, chlorinator, valves and discharge pipes, for constructing the pump house and for the performance of development tests.

All construction equipment shall be in good, serviceable condition and shall be capable of doing the work.

The Contractor shall also furnish all testing instruments, equipment and materials required by the Contractor for his use in ascertaining that construction materials, permanently installed equipment and the finished work conforms to the requirements of specifications and for carrying out all tests required by the specifications to be performed by the Contractor.

Materials to be furnished by the Contractor shall include all materials necessary for the operation and maintenance of the Contractor's equipment and all the materials for installation in the tube well including casing, gravel shrouding, Portland cement, brick, reinforcement, aggregates, electrical conductance, wiring and fittings and all other equipment and materials necessary to perform the work in complete and satisfactory manner.

#### **4.8. CLEAN UP**

Upon completion of construction, equipment installation and operation, test of tube well, the Contractor shall tear down and remove all temporary structures provided and occupied by him, shall remove all plant and refuse, all waste materials; shall remove from the site of the work, or satisfactorily cover with earth.

## **5. DRILLING OF BOREHOLE**

### **5.1. SCOPE OF WORK**

The work covered under the specifications is furnishing all plant, labour, equipment, appliances, and materials, and in performing all operations in connection with the drilling of borehole(s) in strict accordance with this section of specifications in reasonably close conformity with the lines and dimensions shown on the Drawings or established by the Engineer.

### **5.2. DRILLING OPERATION**

Drilling of tube well shall include, but not be limited to moving in, setting up, preparing the site, drilling the borehole, collecting data and removing temporary casing, dismantling, moving out and cleaning up. Measurement for tube well drilling will be made of the actual depth of each borehole drilled, measuring from the original ground surface. No measurement will be made over-drilling required because of the sloughing, caving ground or for the Contractor's use in setting casing; for tube well abandoned due to jammed tools, caving ground, or negligence on the part of the Contractor; or for tube well not constructed in accordance with all the requirements of these specifications.

### **5.3. DRILLING**

The Contractor shall drill each borehole of the diameter indicated on the Drawings and at the locations shown on the Drawings. The Contractor shall prepare the site for the construction of the tube well and shall provide for the disposal of water, cuttings, and refuse from his operation away from the site and to the satisfaction of the Engineer.

The borehole shall be drilled by the reverse circulation rotary method. Each borehole shall be drilled to the depth specified by the Engineer. It is anticipated that the depth of tube well (s) will vary; however, no minimum depth of any individual tube well or average depth for all tube wells is guaranteed. The borehole shall be drilled sufficiently straight and plumb so that the pump and the tube well casing may be installed concentric with the hole and within the tolerance specified for the plumbness of the casing. Waste materials from the drilling operation shall be disposed of in a manner approved by the Engineer.

The Contractor shall be responsible for protecting the tube well from contamination by foreign materials until the completed tube well and appurtenant facilities are accepted by the Engineer. The Contractor shall bear any expense that may result from damage to any tube well, tools or equipment that may be caused by caving, washing or other disturbance within the tube well.

If unstable material is encountered in drilling, the Contractor shall stabilize the material in a manner approved by the Engineer. The use of drilling fluid additives or other suitable materials may be employed for stabilizing the borehole when such use is specifically approved by the Engineer. If necessary, temporary casing shall be furnished and installed by the Contractor to hold walls of the hole during drilling

operations and until the gravel shrouding has been placed. All temporary casing shall be removed by the Contractor in stages as gravel shrouding is placed. The temporary casing may be new or used and will remain the property of the Contractor.

If, in the opinion of the Engineer, it is necessary to discontinue work on any borehole because it is out of line more than the amount specified or on account of jammed tools, caving ground or because of negligence on the part of the Contractor, he will not be entitled to payment for any work done or materials furnished for borehole abandoned as a result of his operations or negligence.

#### **5.4. DATA AND RECORDS**

The Contractor shall keep an accurate drilling log of borehole drilled including description of all materials encountered and their location in the borehole. The fact that the Engineer or his representative may be present and keep a separate record, shall not release the Contractor from this responsibility. In the case of defective or incomplete records, the Contractor shall complete the records at his own expense. All records and data shall be kept by the Contractor on forms approved by the Engineer. The Contractor shall deliver to the Engineer, the original of all records and all such records shall become the property of the Owner.

Representative ditch samples or cuttings of the materials penetrated shall be taken of each lithology encountered and from each ten feet of the depth for non-water bearing depth and each four feet for water bearing depth of the borehole. Special care shall be exercised to determine the thickness and location of each change in material encountered and to obtain satisfactory samples. Immediately upon taking samples, the samples shall be placed in cloth bag, partitioned wooded box, or other approved container, properly marked for identification, and plainly labelled with the depth of the top and bottom of the section of the borehole represented. The containers shall be furnished by the Contractor, the method of obtaining, processing and storing the samples shall be subject to approval by the Engineer. The Contractor shall deliver all samples to the Engineer at the site of the tube well or to the field headquarters of the Engineer as directed.

#### **5.5. MEASUREMENT AND PAYMENT**

##### **5.5.1. Measurement**

The quantity of drilling to be paid for shall be measured by linear meter or linear foot, whichever is included in Bill of Quantities, and drilled as mentioned above.

##### **5.5.2. Payment**

The accepted quantity measured as provided above shall be paid for at the contract unit price per linear meter or linear foot of drilling (whichever is included in Bill of Quantities) of specified diameter of borehole for the pay items included in the Bill of Quantities, which price and payment shall constitute full compensation for furnishing all materials, various drilling operations, labour, equipment, tools and incidentals necessary to complete the item.

Backfilling of the borehole, if a particular borehole is not developed, shall be done as per instructions of the Engineer, payment for which shall be made separately.

## **6. TUBEWELL CONSTRUCTION**

### **6.1. SCOPE OF WORK**

The work shall consist of furnishing all plant, labour, equipment, appliances, and materials and performing all operations in connection with tube well construction except drilling, in accordance with these specifications and in close conformity with the dimensions shown in the Drawings or as established by the Engineer.

### **6.2. CASINGS**

Casing shall consist of all work required in connection with furnishing and installing casing pipe, comprising of steel conductor pipe and steel pump housing pipe and fibre glass / brass or any other specified material, tube well casing (both plain and slotted), required for the tube well and shall include, but not be limited, providing storing, fabricating and installing including concentric reducers and equalizers.

### **6.3. Fibre Glass Strainer & Blind Pipe**

Glass Fibre shall conform to the following specifications:

- ASTM-2996 for Filament-Wound Fibreglass
- ASTM 2997 for Centrifugally Cast Fibreglass

The fibre glass strainer will be from the approved source. The Contractor to this effect will submit for approval of the Engineer, a sample with complete specifications. Prior approval of the material is obligatory and without this approval, the procurement and installation of material will not be accepted for measurement and payment.

### **6.4. Fabrication**

The depth of conductor pipe and pump house casing will be established by the Engineer for the tube well depending upon local sanitary conditions of shallow ground waters. Lengths of specified diameter of steel casing shall be provided to extend the pump housing casing from the elevation of the top of the pump housing casing to the depth established by the Engineer.

Adjoining sections of conductor pipe and pump housing casing shall be assembled by field welding. Butt welding straps shall be provided. All field welding shall be performed by the electric arc method, using heavily coated welding rods suitable for all position welding. After being deposited welds shall be cleaned of slag and shall show uniform sections, smoothness of weld metal, feather edges without overlap, and freedom from porosity and clinkers. The pump housing casing shall be connected to tube well casing with a concentric tapered reducer.

The length and sizes of tube well casing to be installed will be specified for the tube well by the Engineer, and will be sufficient to extend from the bottom of the pump housing casing to the bottom of the tube well. The bottom of the tube well casing shall be fitted with a bail plug. The tube well casing shall consist of slotted sections for installation in the water yielding formation and plain pipe sections in the lowest one

meter of the tube well and opposite non-water yielding formations as directed by the Engineer.

#### **6.4.1. Installation**

The Contractor shall install the entire pump housing and tube well casing assembly straight, plumb, and concentric in the drilled hole to permit the installation of the pump in such a manner that it will operate satisfactorily and without damage. The methods employed by the Contractor in the installation of the casing and in obtaining or correcting the verticality and straightness of the pump housing casing shall be subject to the approval of the Engineer.

Centralizer shall be attached to the pump housing casing so that it will be centred in the drilled hole throughout its entire length and held in such position while gravel shrouding is being placed. Centralizers will be placed at 25-foot intervals throughout the length of the tube well or as directed by the Engineer.

The Contractor shall install the pump housing casing, so that the deviation of its axis from the vertical shall not exceed 35 mm at the bottom of the pump housing casing. Measurements for determination of verticality and straightness of the pump housing casing shall be made by the Contractor in the presence of the Engineer, upon completion of gravel shrouding. Plumbs, pipes and dummies used in these tests shall be approved by the Engineer.

Measurements for determining the deviation of the pump housing casing from the vertical shall be made by the use of a circular plumb having a minimum outside diameter of 15 mm less than the inside diameter of the pump housing casing. The plumb shall hang vertically and shall be suspended in the centre of the casing. When the plumb is lowered to the bottom of the pump housing casing, the line from which the plumb is suspended shall not deviate from the centre of the pump housing casing at the top by more than that corresponding to a deviation of the plumb of 35 mm at the bottom of the pump housing casing. All deviations shall refer to a vertical line passing through the centre of the pump housing casing at the top.

Straightness shall be determined by lowering a section of pipe 40 feet long or a dummy of the same length to the bottom of the pump housing casing. The minimum outer diameter of the pipe or dummy shall be 15 mm less than inside diameter of the pump housing casing. If a dummy is used, it shall consist of a rigid spindle with three cylindrical rings, each ring having a height of at least 300 mm. The rings shall be true cylinders and shall be located at each end and in the centre of the dummy. The central shaft of the dummy shall be rigid so that it will maintain the alignment of the axis of the cylindrical rings. The pump housing casing shall be sufficiently straight so that the pipe or dummy can be passed freely throughout the entire length of the pump housing casing.

The tube well failing to meet the specified requirements for straightness, verticality and concentricity shall be abandoned, and the Contractor shall construct a new well at his own expense at an alternative site designated by the Engineer.

**6.5. GROUTING**

The annular space outside of the conductor pipe shall be sealed with cement grout. The grout shall consist of one part of cement and one part of sand by volume and not more than 5 gallons of water per cubic foot of cement. Grout materials shall be ordinary Portland cement conforming to BS 12, clean sand and clean portable water. The annular space shall be flushed with water prior to grouting to ensure that the space is open and to remove foreign material. The grout shall be applied from the bottom up and in one continuous operation. The grout shall be placed through a minimum 1-inch diameter grout pipe extending to the bottom of the annular space initially and shall remain submerged in the grout during the entire time the grout is being placed to ensure complete filling of the annular space. The grout shall be pumped into the pipe or applied continuously by gravity.

The pipe may be left in place or it shall be gradually removed. In the event of interruption in the grouting operations, the bottom of the pipe shall be raised until all air and water have been displaced from the grout pipe. The grout shall be allowed to set a minimum of 7 days after placement prior to resuming work on the well.

**6.5.1. GRAVEL SHROUDING**

Gravel shrouding shall consist of all work required in connection with furnishing and installing gravel shrouding in the annular space between the conductor pipe and the pump housing pipe, the walls of the borehole and the outside of the casing assembly and in any uncased length of borehole including but not limited to, developing the gravel source, excavating, stockpiling, grading, washing, storing, shipping, and installing gravel shrouding in the tube well.

**6.5.2. Material**

All gravel used for shrouding shall be clean, hard, well-rounded, washed, carbonate free and water-worn, without thin, flat particles and with the gradation as included in Table 3.

**Table 2 - Gradation Requirements for Shrouding Material**

Sr. No.	Sieve	Percentage Passing
1	3/8 inch	100
2	No. 4	60-80
3	No. 7	20-40
4	No. 14	0.50

**6.5.3. Installation**

The specified spaces shall be gravel shrouded by the Contractor from the bottom to the top of the tube well in such a manner that there will be no voids other than the annular space between the gravel particles. The method of placing the gravel, and the

equipment used, shall be subject to approval by the Engineer. Water shall be circulated in the tube well, as the gravel is being laced, by lowering the drill pipe inside the casing and operating the circulation pump. The gravel shall be placed to the top of the tube well and shall be finally settled by bailing after all gravel has been placed. The top of the gravel shrouding shall be maintained at the ground level at all times during development, testing and pumping. Gravel and gravel placement not meeting these requirements will be subject to rejection by the Engineer, and all gravel so rejected shall be replaced by the Contractor at his own expense. Temporary casing, if used, shall be carefully withdrawn in 1-3 meters stages during placement of gravel shrouding and gravel shall be introduced so that each stage of the hole above the bottom of the casing is completely filled before the casing is withdrawn to the next stage. The process of withdrawing the temporary casing is at least 3 meters above the top of tube well casing. Above this point, the temporary casing may be removed or left in place, at the option of the Contractor; however, no payment will be made to the Contractor for temporary casing left in place.

## **6.6. DEVELOPMENT AND TESTING**

Development and testing shall consist of all work required in connection with the development of the tube-well to produce the design capacity of water. It is carried out by breaking the layer of bentonite or sealing clay or compounds in the borehole, and taking out mud, chemical used and fine particles of sand from the shrouding and the aquifer near to shrouding throughout the depth of the tube-well strainer. The development of the well shall be so effective that after its completion the turbidity of water and sand content shall be reduced to minimum permissible limit as recommended by WHO standards. After completion of development of tube-well, the water shall be tested to determine the chemical and bacteriological quality of water, draw down at designed discharge and the specific capacity of tube-well. Any tube-well not developed properly and not meeting above standards shall be rejected and re-drilled. The recovery of tube-well during the test shall also be observed.

### **6.6.1. Method**

The tube-well shall be developed with vertical turbine pumping unit preferably closely coupled with a diesel engine through universal cross shaft which facilitates in pump speed adjustment to draw required discharge from the tube-well. Electric prime mover may also be used but with such arrangement which give variable speeds to the pumping units. The pumping unit shall allow the measurement of water level at any time during operation of the pump; and should be able to reverse its direction of rotation.

### **6.6.2. Equipment Required**

The Contractor shall furnish all the equipment required for the development and testing of the tube-well as indicated below:

- a. Vertical turbine pump with variable speed and reversal in direction of rotation. Capable of discharge twice the rated capacity for the design discharge of the tubewell.
- b. Prime Mover (Electric or diesel) closely coupled with V.T.P. and capable to give a variable/ adjustable speed to the pumping unit.
- c. Discharge Measuring Device, Electronic flow meter, sluice valve for regulation of discharge.
- d. Electronic measuring device to measure water level in tube-well during operation of pumping unit.
- e. Imhoff Cone (Sand Cone)

**6.6.3. Back Wash**

Back washing is done by reversing the direction of the pumping unit for a small time depending upon the condition of the water pumped. The water is pushed back into the aquifer thus stirring the locked sand particles and loosening them for pumping out. Back washing of tube-well shall be done during development at suitable intervals, to pump all fines from the tube-well shrouding. It shall be single backwash if the well is not pumping greater quantity of sand and shall be doubled if it is sandy. The development and backwashing shall be continued till the sand contents are reduced to permissible limit, which shall be checked continuously by Imhoff Cone graduated in PPM (parts per million).

**6.6.4. Duration**

Static water level or sub soil water level shall be measured before start of development.

**a. Development (1<sup>st</sup> Stage)**

Initial development shall be done step wise as included in Table 4

**Table 3 Duration of Development for Tube Well**

S. No.	Discharge	Period of Development
1	0.75 times the designed discharge of tube well	1 hour
2	1.00 times the designed discharge of tube well	1 hour
3	1.25 times the designed discharge of tube well	1 hour
4	1.50 times the designed discharge of tube well	3 hours
5	2.00 times the designed discharge of tube well	3 hours

	Total	9 hours
--	-------	---------

Backwash shall be done every 5-minutes depending upon the sand contents pumped.

**b. Recovery (1<sup>st</sup> Stage)**

Pump shall be stopped after 1st stage of development and well shall be allowed to recover its water table. Reading/measurement of water table shall be taken as provided in the under-mentioned intervals.

**Table 4 Frequency of Measurement during Recovery Period for Tube Well**

Sr. No.	Period (from pump closure)	Measurement Frequency
1	1 <sup>st</sup> 5 minutes	Every minute
2	Up to 15 minutes	Every 2-minutes
3	Up to 30 minutes	Every 5-minutes
4	Up to 1 hour	Every 10-minutes
5	Up to 3 hours	Every 20-minutes
	<b>Total</b>	<b>3-hours</b>

**c. Testing for Development (2<sup>nd</sup> Stage)**

The well shall be pumped in steps as included in Table 4.

Sand contents shall be measured every 5-minutes during each pumping, however during 1<sup>st</sup> five minutes sand content shall be taken every minute. The water level shall be measured in the same way as explained in Recovery period, for each pumping stage and draw down (the difference between the static water level and that during pumping) shall be worked out for each measurement.

**d. Recovery (2<sup>nd</sup> Stage)**

The well shall again be allowed to recover and the measurements of water table shall be carried out in the same way as in the first stage of recovery; Table 10.3.

The difference shall be noted between 1<sup>st</sup> stage and 2<sup>nd</sup> stage of recovery.

**e. Testing for Re-Development (3<sup>rd</sup> Stage)**

The tube-well shall be re-developed for another 9 hours in steps as included in Table 10.2.

Sand contents shall be measured every 5-minutes during each pumping, however during 1st five minutes sand content shall be taken every minute.

The water level shall be measured in the same way as explained in Recovery period, for each pumping stage and draw down (the difference between the static water level and that during pumping) shall be worked out for each measurement.

**f. Recovery (3<sup>rd</sup> Stage)**

Well shall again be allowed to recover for 3 hours and measurements of water table shall be done as in 1st and 2nd stage; Table 10.3. There shall be no difference at the recovery of water table between 2nd stage and 3rd stage. If it is observed that there is an appreciable difference of recovery, well shall be redeveloped for 6 hours with back wash and recovery should again be allowed for 3 hours to match it with 3<sup>rd</sup> stage recovery. The process shall be repeated till the preceding recovery is matched.

**g. Stop Pumping**

The pump shall be stopped for next 4 hours before start of final pumping test for approval of the well.

**h. Final Pump Test**

The tube-well shall be pumped finally for 4 hours at the rated discharge and final draw down shall be noted to find out the specific capacity of the tube-well. Hence the summary of development and testing of tube-well is included in Table 10.4.

Sr. No	Development Step	Time Period
1.	<b>Development</b>	
	Development, 1st Stage	9 hours
	Recovery, 1st Stage	3 hours
2.	<b>Testing</b>	
	Development, 2nd Stage	9 hours
	Recovery, 2nd Stage	3 hours
	Development, 3rd Stage	9 hours
	Recovery, 3rd Stage	3 hours
	Step Pumping	4 hours
	Final Pump Test	4 hours
	<b>Total</b>	<b>44 hours</b>

The duration of development and testing given above is minimum, and may be increased to total duration of 72 hours as per the direction of Engineer.

#### 6.6.5. Performa for Records

Proper Performa shall be developed for development, recovery and testing of the tube-well giving discharge pumped, water level in tube-well, sand contents and timings of the measurements and shall be filled in accurately and precisely. If it seems that there is a mistake in measurement, the process shall be repeated. Proper records shall be kept for each tube-well for subsequent and future references

#### 6.6.6. Operation of Pump & Motor

Power needs to be continuously available to pump during the tests. If power is interrupted, it shall be necessary to terminate the test, allow the well to recover up to initial water level and run a new test. Required pumping rate is to be maintained during the development of the tube-well has been satisfactorily completed and approved by the Engineer. The contractor shall disinfect the tube-well by chlorine solution throughout the entire depth of the well to obtain a minimum chlorine content of 50 parts per million. The procedure and equipment used to introduce and disperse the chlorine in the tube-well shall be approved by the Engineer

#### 6.6.7. Disinfection

After development and testing of the tube well has been satisfactorily completed, and when approved by the Engineer, the Contractor shall disinfect the tube well by dispersing chlorine solution throughout the entire depth of the well to obtain a minimum

chlorine content of 50 mg/l. The procedure and equipment used to introduce and disperse the chlorine in the tube well shall be subject to approval of the Engineer.

### **6.7. SEALING**

Upon completion of disinfections of the tube-well, the contractor shall seal the tube-well by welding the 6mm (1/4") steel plate cap to the pump housing casing around its circumference. Compliance with these requirements will not relieve contractor of his responsibility for safeguarding any complete part of the tube-well until the certificate of acceptance is issued for the entire tube-well installation

### **6.8. MEASUREMENT AND PAYMENT**

#### **6.8.1. Measurement**

The quantity of MS housing pipe, blind pipe and screen of specified material and diameter shall be measured in linear meter or linear foot (whichever is included in Bill of Quantities) of actually installed at site on the basis of tentative quantities included in the Drawings.

The bail plugs, well caps and concentric reducers of specified diameter shall be measured in numbers, actually installed as per Drawings.

Grouting of space between inside of well drilled and outside of housing pipe shall be measured in linear meter or linear foot (whichever is included in Bill of Quantities) of actual executed quantity as per site.

The quantity of gravel shrouding shall be measured in cubic foot or cubic meter (whichever is included in Bill of Quantities) of actual executed quantity as per site.

The measurement for development and testing of tube well shall be measured in hours of testing and development to the satisfaction of the Engineer.

#### **6.8.2. Payment**

The accepted quantity MS housing pipe, blind pipe and screen of specified material and diameter, as above, shall be paid for at the contract unit rate which price and payment shall constitute full compensation for furnishing all materials, labour, equipment, tools and incidentals to complete these items including cost of centralizers (not payable separately).

The bail plug, well cap, concentric reducer of specified diameter/size, gravel shrouding and cement sand grouting, etc shall be paid at the contract unit rate and this price shall constitute full compensation for furnishing all materials, labour, equipment, etc. to complete this item to the satisfaction of the Engineer.

The payment for development and testing of tube well will be made at the contract unit rate which price and payment will be full compensation for all materials, labour, equipment, development, testing, disinfection, etc. as per the specifications and to the satisfaction of the Engineer.

## 7. Hypo-chlorinator

### 7.1. Description

Automatic Mechanical Diaphragm Dozing Pump as Hypo-chlorinator will be installed. The major components in hypo-chlorinator system are:

- Automatic Mechanical Diaphragm Dozing Pump/ Hypo-chlorinator
- Dozing Tank

Based on above components hypo-chlorination at each location will be carried out as follow:

- All the components will be installed in a pump room at each location.
- In each room, Automatic mechanical diaphragm dozing pump/ hypo-chlorinator will be installed on a separate concrete pad having two pipes. One pipe will be for dozing/ injecting hypo-chlorite in the water main to be treated whereas, other pipe will be for taking hypochlorite feed from a dozing tank.
- Hypochlorite will be stored in liquid form in a dozing tank inside chlorinator room. As the shelf life of hypochlorite solution is fifteen days therefore dozing tank will be replaced bimonthly at least which will be a laborious task. In order to avoid this hassle, transfer pump is proposed.

### 7.2. Automatic Mechanical Diaphragm Dozing Pump (Hypo-Chlorinator)

#### General

This specification sets the minimum acceptable requirements for designing, manufacturing, installing, testing and commissioning at Site of Automatic Mechanical Diaphragm Dozing Pump (Hypo-Chlorinator). In case of difference between this specification and the listed international standards then the most stringent requirements shall prevail.

It will be the backbone of Hypo chlorination system because it will inject hypochlorite inside the water main. For this purpose, mechanical diaphragm dozing pump has been approved. Working principle is described below:

- The diaphragm type dozing pump uses a diaphragm to replace the piston. The reciprocating motion under the action of the driving mechanism completes the pump for the suction and discharge process. It is a hydraulically or mechanically actuated positive displacement pump that uses a combination of reciprocating action and either a flapper valve or a ball valve to transfer liquids.
- Diaphragm pumps are self-priming. Diaphragm pumps use the up-and-down movement of a cupped, elastic surface to generate liquid flow. This surface, found within the pump, is typically made from polytetrafluoroethylene (PTFE), Teflon, synthetic rubber or a similar material. When the surface is pushed into the liquid, it adds pressure and displaces a certain amount of fluid. When it is pulled back from the liquid, it draws in more fluid. The diaphragm pump uses check-valves to prevent

the backflow of fluid through the entry valve. The diaphragm design means there is no tubing to fatigue or break due to wear or corrosion.

### Applicable Standards

Automatic Mechanical Diaphragm Dozing Pumps shall comply with the latest revision of the following standards and other relevant standards noted elsewhere in this specification:

*Table 13.1: Applicable Standards for Mechanical Diaphragm Dozing Pump*

Standard	Description
ASME B73.3	Specification for Seal less Horizontal End Suction Centrifugal Pumps for Chemical Process
NEMA MG-1	Motors and Generators
NSF/ANSI 61	Drinking Water System Components
AWWA M20	Chlorination/Chloramination Practices and Principles

### Materials

The minimum acceptable key parameters Automatic Mechanical Diaphragm Dozing Pumps shall be in accordance with **Table 13.2** of this specification.

Table 13.2: General Specifications for Automatic Mechanical Diaphragm Dozing Pump

Sr. No.	Parameter	Least Required Value/Standard
1	Casing	Aluminium with epoxy / acid proof coating
2	Flow Rate	0.5 – 50 L/hr
3	Pressure	12 bar max.
4	Diaphragm Material	Composite PTFE
5	Pump Head Material	PTFE
6	Check Valve	PTFE
7	Valve Ball	Ceramic
8	Suction Lift	1.5 meters minimum
9	Power Supply	230 V AC. ± 10 %, 50 Hz, single phase
10	Inverter Controls	Yes
11	Insulation Protection	IP 65 / NEMA 4X
12	Duty Cycle	Continuous
13	Operating Temperature	60°C maximum

Sr. No.	Parameter	Least Required Value/Standard
14	Accuracy	± 2 % of set point
15	Control Panel Protection	Adhesive polyester film, weather proof and resisting UV ray.
16	Foundation	On Ground with enough space around the pump to facilitate pump maintenance and adjustment. Titanium Anchor Bolts. Canopy will be required if installed outdoors
17	Warranty	All equipment to be furnished shall be warranted for a period of five (05) years after overall completion and trial/stability test run of at least fifteen (15) days.

### Major Features

Given below are the general major features however, the Contractor/ manufacturer/ supplier can propose any advance feature with in the quoted amount for the successful operation:

- Capable of integration into process control systems.
- Flow rate can be changed in order to meet the international standards requirement of the sodium hypochlorite solution used in disinfection of water intended for human consumption.
- Flow rate can be varied using electrical or pneumatic stroke adjustment, or alternatively, by motor speed (frequency converter).
- Easy to read Back Lit LCD Display.
- Display percentage of motor speed & flow rate.
- Built-in Diaphragm Failure Detection System with Alarm.
- Priming / degassing valve.

### 7.3. Dozing Tank

#### General

This specification sets the minimum acceptable requirements for manufacturing, installing, testing and commissioning at Site of Dozing Tank. In case of difference between this specification and the listed international standards then the most stringent requirements shall prevail.

### Applicable Standards

Dozing Tank shall comply with the latest revision of the following standards and other relevant standards noted elsewhere in this specification:

Table 13.3: Applicable Standards Dozing Tank

Standard	Description
ASTM D 1998	Standard Specification for Polyethylene Upright Storage Tanks

### Materials

The minimum acceptable key parameters of dozing tank shall be in accordance with **Table 13.4** of this specification.

Table 13.4: General Specifications for Dozing Tank

Sr. No.	Parameter	Least Required Value/Standard
1	Material	Cross-linked Poly Ethylene (XLPE)
2	Capacity	At least 500 Liters
3	Wall Thickness	The minimum wall thickness shall be in accordance with ASTM D 1998
4	Fittings	PVC. Do not use stainless steel or Alloy C-276 due to nickel content reaction
5	Plumbing	Flexible, Hypo-resistant connections to allow for lateral and vertical tank contraction and expansion and to reduce vibration stress. Connections shall be on lower third of side wall of the tank.
6	Colour	Black, white, blue or grey colour or insulation with mastic coating required in outdoor applications to minimize bleach degradation and maximize chemical half-life.
7	Foundation	Smooth concrete, asphalt or steel foundation
8	Storage Temperature	Product should not exceed 100°F at delivery or during storage to reduce decomposition of the chemical and maintain ASTM D 1998 Parameters. Ideal Temperature is 60°F (15°C).
9	Manway	Fume-tight manway cover
10	Precautions	All cut edges (i.e., manway) shall be trimmed to have smooth edges.

## 7.4. Sodium Hypochlorite

### General

This specification sets the minimum acceptable requirements, sampling and test methods for sodium hypochlorite solution used in disinfection of water intended for human consumption. This specification sets forth a set of minimum physical and chemical properties that must be met. In case of difference between this specification and the listed international standards then the most stringent requirements shall prevail.

### Applicable Standards

Liquid Sodium Hypochlorite shall comply with the latest revision of the following standards and other relevant standards noted elsewhere in this specification:

Table 13.5: Applicable Standards for Transfer Pump

Standard	Description
ANSI /AWWA B 300	Standard for hypochlorite, published by the American National Standards Institute/American Water Works Association
BS EN 901	Chemicals used for treatment of water intended for human consumption – Sodium hypochlorite, published by European Community
NSF/ANSI 61	Drinking Water System Components

### Materials

The hypochlorite solution shall be a pale, yellowish green, clear liquid and shall not produce any sludge or turbidity when mixed with water. The material shall comply with the minimum available chlorine content for not less than 30 days from the date of packing. After the period of more than 30 days, the minimum available chlorine shall be as approved by the Project Manager.

*NOTE - As a guide the following table provides a general guidance on the stability of the material:*

Available Chlorine Trade	Chlorine	Half Life
(Percent)	(g/l)	(Days, 25°C)
3	30	1700
6	60	700
9	90	250
12	120	180
15	150	100

The material, when tested according to the methods prescribed in ANSI /AWWA B 300, shall comply with the requirements given in Table 13.6.

*Table 13.6: Specific requirements for Sodium hypochlorite*

<b>Sr. No.</b>	<b>Parameter</b>	<b>Least Required Value/Standard</b>
1	Available chlorine content, % wt /volume	0.5 to 1.0
2	Total free alkali (as NaOH), % weight by volume	1.2 max
3	Insoluble matter, %	0.15 max
4	Iron (as Fe), ppm	0.4 max
5	Neat pH range	9 - 12

### **Packing, Marking and Storing**

Sodium hypochlorite shall be packed in a suitable airtight container that prevents it from deterioration of its quality during storage, transportation and handling.

Each package shall bear legibly and indelibly the following information:

- a) name and formula of product, 'SODIUM HYPOCHLORITE'(NaOCl).
- b) name and address of the manufacturer.
- c) the net volume of the contents.
- d) the batch or code number.
- e) the nominal available chlorine content.
- f) dates of manufacture and best before.
- g) the instruction for use and handling.
- h) first aid instructions.
- i) the words 'STORE IN A COOL DRY PLACE AWAY FROM DIRECT SUNLIGHT '.
- j) hazard warning in symbol or words.

The material shall be stored in a cool and dark place. While shipping, the material shall be stored away from boilers or any other source emanating heat and light.

## **8. WATER TESTING**

### **8.1. SCOPE OF WORK**

The work covered under these specifications shall consist of collection, transportation, storage, and laboratory examination of water samples for the tube well that has been developed and tested. The water shall be tested for complete chemical and bacteriological examination in accordance with WHO (World Health Organization) Guidelines 1985 or latest edition with the procedures established in the latest version of "standard Methods for Examination of Water and Wastewater" published by American Public Health Association. The examination of water samples shall be carried out in a laboratory approved by the Engineer.

### **8.2. COLLECTION OF WATER SAMPLES**

The water samples shall be collected in separate sterilized containers for bacteriological (i.e., Total Coliform, and Faecal Coliform) and Physio-chemical examination. The samples shall be collected from a tap fitted on the discharge pipe of the pump. The tube well shall be operated at its design capacity for a minimum period of 15 minutes, before collecting the first sample.

#### **8.2.1. Collection for Bacteriological examination**

The volume of each sample intended for bacteriological examination shall not be less than 100 ml. Sterilized glass bottle provided with ground-glass stoppers shall be used for collecting samples. The sample bottle shall not be kept unopened until the moment, it is required for filling. During sampling, the stopper and neck of the bottle shall be handled to protect from hand contamination. The bottle shall be filled without rinsing and the stopper shall be replaced immediately after the bottle is filled.

#### **8.2.2. Collection for Physio-Chemical Examination**

The volume of each sample shall be at least 2 litres. The samples shall be collected in a chemically clean bottle, made of practically colourless glass and fitted with a ground-glass stopper. The bottle shall be rinsed at least three times with the water that is to be sampled before bottle is filled. While sampling, the bottle shall be held near its base.

### **8.3. TRANSPORTATION AND STORAGE OF SAMPLES**

With the water samples intended for bacteriological examination, the laboratory procedures shall be started as soon as possible, preferably within one hour of collection. However, the time elapsing between collection and examination of samples shall in no case exceed 24 hours. During the elapsing between collection and examination, the temperature of samples shall be maintained as close as the time of sampling.

Water samples intended for physio-chemical examination, the samples shall be kept cool during transport and storage. The time elapsing between collection and examination shall in no case exceed 48 hours.

## **8.4. LABORATORY EXAMINATION**

Following methods shall be used for determination of turbidity, colour, total dissolved solids, chlorides, total coliform and faecal coliform, in the water samples:

### **8.4.1. Turbidity**

The turbidity shall be determined by Nephelometric method as described in the "Standard Methods". The turbidity of samples shall be measured and reported in Nephelometric Turbidity Unit (NTU).

### **8.4.2. Colour**

The true colour of sample shall be determined by comparing it with Nessler colour comparison tubes. The colour shall be determined and reported in colour units based on Platinum-Cobalt scale.

### **8.4.3. Total Dissolved Solids**

The total dissolved solids shall be determined by Filtration-Evaporation method and expressed in mg/l.

### **8.4.4. Chlorides**

Chlorides shall be determined by employing Mohr method, which uses silver nitrate as titrant and Potassium Chromate as the indicator. Chlorides shall be expressed and reported in units of mg/l.

### **8.4.5. Total Coliform and Faecal Coliform**

Total coliform and faecal coliform concentrations shall be determined by employing Standard Methods. Dilution-Tube Technique shall be used. The results shall be reported in units of MPN/100 ml.

## **8.5. RECORD & DATA**

A record shall be made of each sample by the Contractor and each bottle shall be identified including the information sufficient to identify the sample at some later date i.e. name of sample collector; date, hour, and location of sampling and water temperature. All records and data shall be kept by the Contractor on forms approved by the Engineer.

## **8.6. MEASUREMENT AND PAYMENT**

### **8.6.1. Measurement**

The measurement shall be made for each sample, tested in accordance the provisions of this section of the document and accepted by the Engineer.

### **8.6.2. Payment**

Payment shall be made for each set of samples tested and measured as above, at the unit rate appearing in the Bill of Quantities. This price and payment will be full compensation for all steps required to complete the work.

## **9. CONSTRUCTION OF PUMP HOUSE**

### **9.1. SCOPE OF WORK**

The work shall consist of construction of pump house complete as per Drawings and in accordance with these specifications and in close conformity with the lines, grades and dimensions shown on the Drawings or as established by the Engineer.

### **9.2. MATERIALS AND CONSTRUCTION REQUIREMENTS**

Materials and construction requirements shall conform to the respective items included in the document.

### **9.3. MEASUREMENT AND PAYMENT**

#### **9.3.1. Measurement**

Lump sum or item rate, whichever is included in Bill of Quantities, will be the basis for measurement for the item of various works involved for the completion of this item.

#### **9.3.2. Payment**

When the bill of quantities calls for a lump sum price, construction of pump house will be paid for at the contract unit rate which price and payment will be full compensation for all miscellaneous operations for all civil, electrification, lights, fans, complete as shown on the Drawings or established by the Engineer.

## **10. ELECTRICAL & MISC. WORKS**

### **10.1. SCOPE OF WORK**

The work shall consist of furnishing all plant, labour, equipment, appliances, and materials and of performing all operations in connection with the electrical work and other works in strict accordance with this section of the specifications and the applicable Drawings, and subject to the terms and conditions of the contract.

### **10.2. ELECTRICAL WORKS**

#### **10.2.1. Regulation**

All electrical installation work shall conform to the Electricity Act, 1910 and the Electricity Rules 1937, as adopted and modified by the Government of Pakistan from time to time and WAPDA/PESCO Specifications; and the requirements specified herein. Except where otherwise shown or specified all electrical equipment shall be suitable for operation 230 volts, 50 cycles, alternating current power supply. All electrical materials shall be new. Defective equipment or equipment damaged during installing or testing shall be replaced or repaired by the Contractor at his own expense.

#### **10.2.2. Coordination**

The Drawings indicate the extent and the general location and arrangement of equipment, conduit and wiring. The Contractor shall study building plans and details so that the outlets and equipment will be properly located and readily accessible. Lighting fixture equipment and outlets shall be located to avoid interference with mechanical or structural features; otherwise, lighting fixtures shall be symmetrically located according to building arrangement. If any conflict occurs necessitating departure from the Drawings, details of departure and reasons therefore shall be submitted as soon as practicable for written approval of the Engineer.

#### **10.2.3. Standard Products**

Material and equipment used for this work shall be standard products from manufacturers regularly engaged in producing such equipment and shall be the manufacturer's latest standard design complying with specification requirements.

#### **10.2.4. Material and Equipment Schedules**

As soon as practicable and before starting installation of any material or equipment, the Contractor shall submit 6 copies of a complete list of materials and equipment proposed for installation to the Engineer for his approval. The list shall include manufacturer's names and materials or equipment identification such as styles, types, or catalogue numbers, to permit ready and complete identification.

#### **10.2.5. Workmanship**

All materials and equipment shall be installed in accordance with recommendations of the manufacturer subject to approval by the Engineer and in such a manner as to conform to the contract documents.

### **10.2.6. Grounding**

All electrical equipment, including motors, meters, lighting and distribution panels, switchgear and similar items shall be grounded. All exposed non-current carrying metallic parts of electrical equipment, raceway systems and neutral conductor of the wiring system shall be grounded. Earth plates for the grounding system shall consist of copper plates of the minimum size of 609.6mm square and 3.175mm thick. The top earth plate shall be 2.44m below the ground level with critical watering arrangement or at the natural water level whichever is easy to install. A minimum 152.4mm layer of charcoal and rock salt shall be provided underneath each earth plate and a minimum 457.2mm layer of charcoal and rock salt shall be provided above each earth plate. The ground connection from the earth plate shall be securely bolted by a copper nut and bolt and additionally soldered to the plate. The ground connection including earth plate shall be kept clear of the structure foundation. The earth plate shall be located not nearer than 1.83m from the outer face of the building wall. Ground connections indicated as 3.18x25.4mm copper tape may be made with number 4/0 AWG or SWG cable. Ground connections indicated as 3.18mm by 12.7mm copper tape may be made with number 2/0 AWG or SWG cable. All ground connections shall run vertically and horizontally exposed on the surface of the wall and shall run concealed in the floor. Connections and splices shall be of the brazed, welded, bolted, or pressure connector type, except that pressure connectors or bolted connections shall be used for connections to removable equipment. Ground connection from the building to the earth plate shall be run at a depth not less two feet below ground level.

### **10.2.7. Conduit**

Unless otherwise indicated, electrical wiring shall be run in galvanized steel (G.I.) conduit or PVC Pipe according to the specification PVC pipe shall not be used as conduit for buried or embedded run. Minimum size of raceways for branch circuit wiring shall be 19.1mm. Conduit pipes shall be exposed on walls and ceilings but shall run concealed in floors. Conduit shall be continuous when passing through wall or floor. Conduits installed on the surface of walls shall be supported and secured at intervals of not more than 0.91m and shall be installed parallel or perpendicular to walls, structural members or inter sections of vertical planes and ceilings. Field made bends and offsets shall in general be avoided, but if so required these shall be made with an approved method or by conduit bending machine. Changes in direction of runs shall be made with symmetrical bends or cast-iron fittings. Crushed or deformed raceways shall not be installed. Trapped raceways in damp and wet locations shall be avoided where possible. Care shall be taken to prevent the lodgement of plaster, dirt or trash in raceways boxes, fittings, and equipment during the course of construction. Clogged raceways shall be entirely free of obstructions or shall be replaced. Raceways crossing expansion joints in concrete slabs shall be provided with suitable expansion fittings or other suitable means to compensate for expansion contraction. Raceways installed underground or under slabs shall be coated with an approved type of protective coating.

**a. Galvanized Iron (GI) Conduits**

The galvanized iron (GI) conduits shall have minimum wall thickness of 1.65mm (i.e., 16 SWG) and shall have the diameter indicated on the Drawings. Damaged portions of galvanizing at joints shall be cleaned and painted with a silver-coloured rust inhibitive paint. Conduit shall be cut and threaded in such a manner that there are no sharp edges. Conduit bends shall be uniform and shall have minimum radius of 5 times the diameter of the conduit or shall be made through pull or junction boxes.

**b. PVC Pipe**

PVC pipe and specials shall conform to British Standard Specification BS 3505:1962 "Unplasticized PVC pipe (Type 1420) for Cold Water Supply" and shall be class B. The entire conduit system shall be completed by cutting the PVC pipes and jointing and sealing to respective specials with P.V.C. solution as recommended by the PVC pipe manufacturers.

**c. Additional Requirements for Exterior Conduit**

All joints between sections of conduit, conduit and specials, and conduit and switches or lights shall be made water proof in an approved manner. Except where otherwise indicated, conduit shall be supported at least every 0.914m. Drainage fittings or seep holes shall be provided at unavoidable low points where moisture can collect. A maximum of two 90-degree bends will be allowed between boxes. Conduits shall be buried underground at minimum of 457.2mm below finish grade. Bearing of conduit shall be uniform throughout its length in bottom of trench. Backfilling shall be in 101.6x152.4mm layers, compacted to 95 percent of maximum density.

**10.2.8. Conductors****a. General**

Conductors shall be new and shall be of polyvinyl chloride (PVC) insulated copper unless otherwise specified. Wire connector of insulating material or solderless pressure connectors properly taped shall be utilized for all splices where possible soldered mechanical joints insulated with tape shall be kept to a minimum. Vinyl plastic tape of suitable quality is acceptable in lieu of rubber and friction tapes. The entire conduit system shall be completed and anchored prior to installing the wiring.

**b. Conductor Sizes**

Conductor sizes for tube-well motor main cables shall be as indicated in the Drawings. Control circuit conductors shall not be smaller than number 12 AWG except that for circuits of more than 30.48m from panel to load centre number 10 AWG shall be used.

**c. Conductor Insulation**

In normally dry locations, conductor number 8 AWG or larger shall have rubber or thermoplastic insulation of a heat resistant grade RH, RW, RHH or

THW. Conductors smaller than number 8 AWG shall have a heat resistant rubber insulation type RH or RH RW or thermoplastic insulation, type T or TW.

#### **10.2.9. Boxes and Supports**

Boxes shall be provided wherever required for pulling of wires, making connections, and mounting devices or fixtures. Boxes for metallic raceways shall be of the cast iron hub type when located in normally wet locations. Boxes in other locations shall be sheet steel except that non-metallic boxes may be used with non-metallic conduit system. Steel boxes shall be fabricated of structural quality flat rolled minimum 18-gauge sheet of steel free from irregularities, mill scale and surface corrosion shall be neatly and accurately formed with corners squared and sides jointed by welding. Each box shall have the volume required for the number of conductors enclosed in the box. Boxes for mounting lighting fixtures shall be not less than 4 inches. Cast iron boxes installed in wet locations and boxes installed flush with the outside of exterior surfaces shall be gasketed. Boxes for use with raceway systems shall not be less than 38.1mm deep. Exterior pull boxes, junction boxes, boxes for exterior electrical supply points, switch boxes and all other boxes required for exterior electrical work shall be weather proof, heavy duty, galvanized steel.

#### **10.2.10. Lamp Fixture and Accessories**

All incandescent lighting fixtures shall be suitable for bayonet base lamps. All accessories such as straps, mounting plates, nipples or brackets shall be provided as required for proper installation. The exterior light points shall be provided with all fittings, accessories, metal clad switches, weatherproof light fixtures, holders, bulbs and covers.

#### **10.2.11. Electrical Supply Points (Outlet Connections)**

Electrical supply points shall be provided where indicated on the Drawings. Electrical supply points shall have the types of receptacles suitable for the plugs of the equipment to be connected to these points. Where receptacles are not available to match the plugs of equipment, standard receptacles shall be used and plugs on equipment supply leads shall be replaced by the contractor with plugs to match standard receptacles. Each electrical supply point shall be complete with a switch. Exterior electrical supply points shall be provided where indicated. Exterior electrical supply points shall be weather proof, complete with switch and of the type suitable for the plugs of the equipment to be connected to these points.

#### **10.2.12. Flexible Connections**

Flexible connections of short lengths shall be provided for all motors and equipment. The flexible connections shall be water tight.

#### **10.2.13. Fuse Circuits and Fuse Boxes**

The Contractor shall provide proper fuse boxes for each circuit. The fuse boxes and the switches shall be metal clad and suitable for the load for which the circuit is

designed. All fuse boxes shall be complete with proper size fuse strips fitted to fuse bridges.

#### **10.2.14. Power Switchgear Assemblies**

Power switchgear assemblies shall be metal enclosed and air circuit breaker type. The type and make of the circuit breaker shall be subject to approval of the Engineer.

#### **10.2.15. Exterior Switches**

Except where otherwise indicated exterior switches shall be of the push button weatherproof type.

#### **10.2.16. Testing**

Before any electrical system is put into service, the entire system installation shall satisfactorily pass the tests prescribed by the Electricity Department and the following tests. The Contractor shall furnish all instruments and personnel required for the tests, and the Client will furnish the necessary electric power.

##### **a. Insulation Resistance**

The insulation resistance shall be measured by applying voltage between earth and the entire system of conductor or any section thereof, with all fuses in place and all switches on. A direct current voltage of not less than twice the working voltage shall be applied. The insulation resistance of the installation measured as above shall not be less than 25 megaohms divided by the number of points in the circuit. The metal conduit shall be tested for electrical resistance. The electrical resistance of such conduits measured between the main switch and each point shall not exceed 2 ohms.

##### **b. Operating Test**

After the wiring system has successfully passed by the insulation resistance test, and at such time as the Engineer may direct, the Contractor shall conduct an operating test for approval. The equipment shall be demonstrated to operate in accordance with the requirements of this specification. The test shall be performed in the presence of the Engineer.

##### **c. Earth Plate Resistance**

Resistance to each earth plate shall be tested by a standard earth tester, not sooner than 72 hours after a rain and without prewetting ground. The resistance of each earth plate shall not be more than 10 ohms. The test shall be performed by the contractor in the presence of the Engineer. Earth plates having a resistance of more than 10 ohms shall be replaced and retested. The Contractor shall submit in writing to the Engineer upon completion of the project, the measured ground resistance of each earth plate, indicating the location of the earth plate and the resistance and the soil conditions at the time, the measurements were made.

### **10.2.17. Repair**

The work shall be carefully laid out in advance. Cutting, channelling, chasing or drilling of floors, walls, partitions, ceilings or other surfaces as necessary for the proper installation, support or anchorage of the conduit, raceways or other electrical work shall be carefully done. Damage to building surfaces, piping and equipment (including pointing work) shall be repaired to its original condition by skilled mechanics of the trades involved at no additional cost to the Client.

## **10.3. POWER TRANSFORMER**

### **10.3.1. General**

The power transformer shall be indoor type, oil immersed, self-cooled, designed and built to give efficient and reliable service at their full rated capacity on the climatic conditions given in the general information of these specification. Transformers built to the following standard will be acceptable.

- BS 171-1970 or any other relevant latest British Standard
- VDE 0532

### **10.3.2. Construction**

The transformer tank shall be constructed of welded sheet steel plates and provided with external radiating tubes.

The transformer shall be fully tropicalized for temperature rise, humidity, altitude etc. The local conditions shall be taken into account while following the above standards. The transformer shall be complete with oil filling, all accessories and attachments detailed in these specifications or otherwise required and the contractor shall provide all details, drawings, data and complete test results for final approval before installation. The tank and radiating tubes shall be designed to withstand, without developing any deformation, pressure at least 25% greater than the maximum operating pressure. The steel plate cover shall be bolted to the tank, using gasket for perfect oil seal. Two earth terminals shall be provided at the base of the tank.

The oil preservation system shall utilize on expansion the conservative tank fitted with silica gel breather and oil level indicator.

The transformer core shall be built of high-grade electrical steel laminations, each lamination insulated to reduce eddy current losses. The core laminations shall be clamped and bolted effectively to reduce 'humming'.

The winding core shall be of high-grade electrolytic copper conductor, flat or round paper insulated, thoroughly dried and impregnated as desired.

The high voltage leads shall be brought out and terminated to glazed porcelain insulator bushings for external connection.

The low voltage three lines and neutral leads shall be brought out and terminated to glazed porcelain insulator bushings for connection to L.V. side by copper bus bars or cables. The transformer neutral shall be earthed.

Off-load operated tap changer shall be provided on the tank cover. The tapping shall be -7.5%, ±5%, ±2.5%. A clear marking illustrated by diagram shall be provided to indicate the tap positions.

The transformer shall be provided with the following accessories.

- Oil filling valve for vacuum filling of oil;
- Oil drain plug;
- Bi-directional rollers fixed to the base steel channel, for rolling in the directions of both centre lines of the transformer;
- Lifting lugs, for handling and un-tanking the transformer; and
- Dial type thermometer for indicating oil temperature and having two hands, one showing existing oil temperature and other showing maximum oil temperature reached since the hand was last reset.

**10.3.3. Drawings and Data**

The manufacturer shall supply complete structural Drawings showing plan and elevations with complete dimensions and all relevant details of technical data of the offered transformer.

**10.3.4. Transformer Technical Data**

The technical data for Power Transformer shall be as included in Table 13.1.

**Table 5 - Technical Data for Power Transformer**

Sr. No.	Parameter	Data
1	KVA rating	As shown on Drawings
2	No load ratio	11kv/415 V
3	H.V. Winding	
	Line to line volts	11000
	Connections	Delta
4	L.V. Winding	
	Line to line volts	415
	Connections	Star
5	Vector Group	DY 11
6	Tapping on H.V side	-7.5%, ±5%, ±2.5%
7	H.V Termination	Bushing
8	L.V cable size	7x300 mm <sup>2</sup>
9	L.V Termination	Bushing
10	Impedance voltage	4.5% to 6%
11	Losses in watts	

	Iron at no load	to be furnished by Bidder
	Copper at full load	to be furnished by Bidder
12	Cooling	On
13	Temperature rise over 50°C ambient	
	Oil	40°C
	Winding	50°C

**10.4. MEASUREMENT AND PAYMENT**

**10.4.1. Measurement**

The measurement of each item shall be as per provisions of the bill of quantities.

**10.4.2. Payment**

The items will be paid for at the contract unit price which price and payment shall be full compensation for furnishing, installing and commissioning all machinery and equipment for electrical works, chlorination equipment etc. complete in all respects as shown in the Drawings including all labour, tools, equipment and incidental to complete the work.

## **PART-C SOLAR WORKS**



## 11. SOLAR PANELS

- a. The PV module(s) shall contain N-Type Mono crystalline silicon Grade-A Solar cells (Bifacial Double Glass Modules due to its better performance will be given preference).
- b. The PV module should Work well with high-voltage input Inverters (charge controllers (>21500 Vdc).
- c. The PV Panel must have clear anodized aluminium frame with Anti-reflective, hydrophobic, low-iron Tempered cover lass.
- d. The Solar Modules shall meet the following valid IEC Standards or latest:
  - (IEC 61215-1;2021, IEC 61215-1-1 2021 & IEC 61215-22021) (Design Qualification)
  - IEC61730-1 :2023 (Safety - Requirements for construction)
  - IEC61730-2:2023 (Safety - Requirements for testing)
  - IEC TS-62804-I-I (i.e.: TUV PPP-58042B or Equivalent) Anti-PID Certification.
  - IEC 61701 :2020 Salt Mist Corrosion Resistance Test.
  - IEC 62716 Ammonia Corrosion Resistance Test (Latest).
  - IEC 60068-2-68 PPP 59022A sand and Dust Erosion Resistance Test.
- e. Unique Serial number, Name / Logo of manufacturer and separate date of manufacturing (DD/MM/YYYY) should be laminated inside the module so as to be clearly visible from the front side /Factory Acceptance Test (FAT), for Verification of Manufacturing Facility / Process and Product.
- f. A properly laminated sticker containing the following details should be available at the back side of the module.
  - Name of the manufacturer/ distinctive logo
  - Model Name and Type of Cell Technology
  - Peak Watt Rating (Wp) and Power Tolerance Range
  - Voltage (Vmp) and Current (Imp) at STC
  - Open Circuit Voltage (Voc) and Short Circuit Current (Isc)
  - Minimum System Voltage (Vdc) (i.e.≥1500 Vdc)
  - Test Standard(s) to which the module has been tested and certified
- g. Following, essential technical parameters of solar panel/modules should be provided with each panel supplied as well as in the technical proposal.
  - I-V curve for the solar photovoltaic module/panel.
  - Date and year of obtaining IEC PV module standardization qualification certificate.
  - Electrical Data (i.e.: Pmax, Voc/Vmp, Isc/Imp at nominal Cell Operating Temperature (NOCT).
  - PV Module efficiency at STC.
  - Working temperature range of PV Module.

- h. Each panel should have factory equipped weather proof terminal junction box having at least IP67 protection with provision of opening for replacement of DC cables, blocking diodes and easy debugging if necessary.
- i. Limited performance guarantee: panel power, in standard conditions, will not be less than 90% of nominal power by the end of 10 years of operation and at least 80% at the end of 25 years of operation with 25- year limited power warranty.
- j. The PV Module should have at least 10-years warranty for any defects and efficiency as mentioned above. It should be provided On Stamp Paper (Signed and Stamped by Contractor) at the time of Handing/Taking Over or signing of contract agreement.
- k. The PV modules shall have a minimum efficiency of 22.0%, along with positive power tolerance. However, for solar street lighting projects, a module efficiency of 17.5% with positive power tolerance shall remain acceptable.
- l. The PV modules offered should not be more than 12 months old from the date of issue of work order.
- m. PV Module should have minimum Snow Load bearing of 5400 Pa and Wind Load Bearing of 2400 pa however if department deem appropriate may go for 3800 pa wind loads depending upon their requirement.
- n. The Solar Module should be free from visual and cosmetics defects.
- o. The department/consultant on the expense of contractor/supplier shall verify Flash test reports with serial numbers from manufacturer for each panel (at the time of supply).
- p. All information regarding solar panel with above mentioned featured data should be accessible and verifiable online on the manufacturer website.
- q. IEC Certification should be accepted only from an IEC accredited lab for Solar Panels.
- r. Electroluminescence (EL) test may be performed randomly for each project at the cost of contractor/supplier.

Note: For the purpose of verification/ third party validation the Electroluminescence (EL) and Flash testing of randomly sampled PV modules should be conducted.

#### **11.1. CABLES, WIRING AND PROTECTION DEVICES:**

- a. The AC/DC cables shall be made of 99.9% (allowing a tolerance of  $\pm 0.1\%$ ) copper strands and flexible.
- b. From PV Panel to Junction Box / T-Branch/Inverter, use single-core, double-insulated (UV-stabilized cables with XLPO insulation and XLPO/PVC sheathing). Cables must be stranded or flexible type and shall preferably conform to EN 50618 or IEC FDIS 62930 standards.

- c. From JB to Inverter, the DC cable must have Single core, double insulated and suitable for minimum  $\geq 1500$  VDC transmission.
- d. From Inverter to batteries, the DC cable Can be single insulated, Single Core and suitable for minimum  $\geq 600$  VDC- transmission.
- e. DC circuit breakers/Fuse of  $\geq$  Voc of String Voltage and suitable ampere rating (1.25 to 1.50 Times of Rated Current of all strings connected) must be installed between PV modules and controller / inverter.
- f. AC Circuit Breaker (s) of suitable rating (1.25 to 1.50 Times of connected Load) must be installed between Controller / inverter to Load and Grid to Controller / Inverter.
- g. AC / DC breakers should be marked with the manufacturer model number, rated voltage, ampere rating and batch/serial number.
- h. DC / AC breakers rating should be approved from Engineer In-charge before installation at site.
- i. To prevent solar panels from damage an appropriate size of DC Breaker/Fuse should be installed for each PV string and Surge Protection should be installed for combined Array (before Main DC Breaker / Inverter).
- j. DC Breaker, AC Breaker & Change overs should be placed in Junction box. For outdoor installation Junction boxes should be Hot Dipped Galvanized with minimum thickness of 16 SWG.
- k. Cables shall be clearly labelled with essential electrical parameters including manufacturer name, Voltage Range, standards etc.
- l. All DC Wiring shall be aesthetically neat and clean, over - all wiring/connection losses shall not exceed 1% of the total rated output power.
- m. All connections/ socket outlet among array, controller, inverters, batteries, and pumping set etc. must be made in junction boxes of adequate protection level.
- n. All wires/cables should be in standard flexible UV-Resistant conduits / HDPE of PNI2, SDR 13.6, PE 100 for outdoor installation & (1-3 feet deep) for underground wiring / Cabling and PVC ducts for indoor installation.
- o. The DC Combiner Junction Box should be properly earthed including earthing of door as well.
- p. The DC Combiner should contain proper bus bars of adequate size, each for Positive, Negative and Earthing
- q. The Inverter Junction Box should be properly earthed as well as per vetted design of the Engineer in charge.
- r. All wiring should be in proper conduit of capping casing. Wire should not be hanging loose.

- s. All wires should be terminated properly by using lugs/thimble connectors/sleeves.
- t. Distribution board must be installed with proper screws.
- u. Electrical Hazards Safety Labels should be pasted on DC Combiner /VFD Enclosure / Charge Controller /Battery Enclosures.
- v. Following third party lab tests are mandatory:
- w. Conductor resistance test, Insulation resistance test, Pressure test & Spark test, copper purity test, cable size test or any other necessary tests recommended by Engineer.
- x. DC Cable from PV Module to junction Box / Inverter for each string should be 6 mm'
- y. DC Cable Sizing from Junction Box to Inverter (up to cable length of 200 ft) as per details below.

S.No	No of Strings	Cable Size (mm <sup>2</sup> )	Remarks
1.	1	6	If Cable length is >200 ft (One Sided) than cable size should also be increased accordingly.
2.	2	10	
3.	3	16	
4.	4-5	25	
5.	6-8	35	

- z. Over Voltage / Current Protection Device may be installed between Utility &Inverter.
- aa. Surge protection may be installed for combined Array (before Main DC Breaker/ Inverter). aa. Cable colour coding should be adopted in accordance with relevant international standards.

Note: - To ensure compliance with the above specification. the Conductor resistance test, Insulation resistance test, Pressure test, Spark test, copper purity test & cable size test may be conducted through any accredited laboratory in Pakistan.

**11.2. PANEL MOUNTING & STRUCTURE:**

- a. The panel mounting and structure should be made of hot dipped (80 microns Average) galvanized steel of minimum thickness of **12 SWG Channel! Pipe or 8 SWG Angle** (Sketch and Profile of channel / Angle is Attached for Reference).

- b. A sketch of the mounting frame (As per Actual Site Requirements) showing dimensions of the frame parts should be provided at the time of supply.
- c. PV to ground clearance must not be less than 1.0 feet. The height of the upper edge of the structure should be up to 10 feet above the ground / Rooftop Installations.
- d. To avoid Shading, Distance between two rows of PV panels and from walls should be maintained at a minimum of 1.6 times the height of structure/walls. PV shading analysis may be conducted using Helioscope, SketchUp, PVSOL, PVsyst, or any other suitable software or tool.
- e. For ground-mounted installations, the concrete foundation pit size shall be a minimum of 1.5 ft x 1.5 ft x 2.0 ft for each individual leg, or 1.5 ft x 3.0 ft x 2.0 ft for a double-leg structure. The concrete must extend at least 1.0 ft above the ground level. For rooftop installations, the civil foundation blocks for each individual leg should be approximately 0.7 ft to 1.0 ft (length) x 0.7 ft to 1.0 ft (width) x 0.7 ft to 1.0 ft (depth), depending on structural requirements. The concrete mix ratio shall be 1:2:4 for all civil works.
- f. The Surface azimuth angle of PV Module  $180^{\circ} \pm 30^{\circ}$  and the Tilt angle (slope) of PV Module be preferably  $33^{\circ} \pm 15^{\circ}$ . As per site requirements, further azimuth / tilt angle changes (if required) can be made with the approval of Engineer In-charge.
- g. The PV modules will be mounted on metallic structures of adequate strength and appropriate design, which can withstand load of modules and high wind velocities up to 150 km per hour.
- h. Due to land non-availability or any other problem, Structure design can be modified as per site requirement. Pole Mounted or manual Tracker or H beam Mounting Structure with (Enamel Paint & Red-Oxide) can be provided with the approval of Engineer In-Charge.
- i. Array fasteners (nut/bolts/washers) between PV Module and Structure shall be stainless steel (Non – Magnetic). Washers should be installed on both sides Of Module frame.
- j. The minimum space between two PV Modules should be 2.54 cm (1 inch), to avoid air push over PV Modules.
- k. Mechanism / arrangement for cleaning of PV Panels should be provided. i.e.: Space /ladder between panels or at the back side of structure, so that the operator can safely climb and clean the panels.
- l. All other array fasteners Structure shall be stainless steel (Non-Magnetic) or Hot Dipped galvanized steel that provides the required mechanical strength. Washers should be installed on both sides.
- m. The PV modules will be mounted on metallic structures at the inner holes for cantilevered installation, which will evenly distribute the load of the panel around the support structure on both sides and in the middle.

- n. All fabrication work (welding, cutting, or drilling) and Structural modifications must be completed prior to the galvanization.

**Note:** For strength and durability of the Mounting Structure the stress & strain test may be conducted from any accredited laboratory of Pakistan.

### **11.3. EARTHING/ GROUNDING:**

- a. The PV panel frame, supporting Structure, electrical cabinet, protection devices, and all associated equipment should be grounded using the shortest practical route to an effective earth point with a low resistance (ohmic) value, in accordance with the equipment manufacturer's recommendations and site-specific soil conditions. An uninterrupted grounding conductor shall be employed to maintain electrical continuity. Effective grounding significantly reduces the risk of damage from lightning-induced surges and electrical faults.
- b. The Sizing of Earthing conductor will be done as per NEC Table 250.122 (Mentioned at Appendix-VI).
- c. The grounding conductor should be 99.9% (allowing a tolerance  $\pm 0.1\%$ ) copper and PVC insulated / Bare Copper if installed underground along a defined path where size & Design shall be approved from Engineer In-charge before installation at site.
- d. Motor, inverter, Battery / Battery Box (if required), Main Distribution Board should be connected to an adequate earth contact / Grounding,
- e. Ground enhancement material (GEM) shall be used below and above the Earthing plate for proper grounding. Gravel or coarse sand shall be poured along with soil in the pit.
- f. Grounding / Earthing plate should be made of copper plate of 4mm thickness & Size minimum 1.0 x 1.0 Ft.
- g. Grounding / Earthing conductor should be connected to the plate / Rod / GI Pipe by proper connector of minimum depth of 6 feet.
- h. All nut / bolt and Earthing clamp shall be stainless steel or galvanized steel or any other material as per approval of Engineer In-Charge.
- i. Alliteratively, Earthing Rod/Plate of suitable size and length can be installed, if given / mentioned in the BOQ/Design and Engineer In-Charge Approval.

### **11.4. BATTERIES:**

- a. The battery should be Deep Cycle, GEL, OPzV/OPzS, Lithium LiFeP04, Sodium-ion, Lead Carbon, Super Capacitor based Battery or equivalent.
- b. The battery must ensure safe and reliable operation in the whole range of ambient temperatures from  $-5^{\circ}\text{C}$  to  $+ 50^{\circ}\text{C}$ .

- c. The maximum permissible self-discharge rate should not be more than 5 percent of rated capacity per month at 25° C.
- d. The battery shall have a certificate of compliances, issued by a recognized laboratory.
- e. Deleted
- f. The battery shall meet the requirements and recommendations given in IEC 61427, IEC 60896 21/22 (For VRLA) equivalent. Lab Test for battery/Cell cycle life (All Batteries Type) should be provided.
- g. The Battery must support parallel and series connection to allow for capacity expansion in the future.

Each Battery should have followed minimum information printed on battery:

- Model Number, Serial Number and Type of battery.
  - Rated Voltage and Capacity (AH) at 25°C at discharge rate of 10 Hours.
  - Origin of made
  - Manufacturer Name / distinct logo.
- h. The following information must be provided in the data sheet while submitting technical bid.
    - Certification/Test Standard (s) of the battery.
    - Information regarding cycles & self-discharge rate
  - i. In case of rechargeable battery bank (having more than one battery), the interconnection shall be made using lead plated bus bars or properly insulated flexible copper conductors.
  - j. Battery disconnect switch / breaker of suitable size should be installed between batteries and inverter /charge controller.
  - k. The Battery must have Low self-discharge rate, No memory effect and No gassing.

Note: The battery Capacity (kWh) test along with charge & discharge curves may be conducted through an accredited laboratory in Pakistan.

## **5.1 GEL BATTERIES:**

- 5.1.1 Cycle life Of the GEL battery (12 V) must be minimum **1000** cycles 50% depth of discharge (DOD) at discharge rate of 0.1 C@25°C (before reaching 80% capacity of its Initial Capacity).
- 5.1.2 Cycle life Of the GEL battery (2V Cell) must be minimum 1300 cycles 50% depth of discharge (DOD) at discharge rate of 0.1 C@25°C (before reaching 80% capacity of its Initial Capacity).
- 5.1.3 The Batteries should have two-years Comprehensive replacement warranty.

## **5.2 Lead Carbon**

- 5.2.1 Cycle life of the Lead Carbon battery (12 V) must be minimum 2000 cycles 50% depth of discharge (DOD) at discharge rate of 0.1C @25°C (before reaching 80% capacity of its Initial Capacity).
- 5.2.2 Cycle life of the Lead Carbon battery (2V) must be minimum 2500 cycles@50% depth of discharge (DOD) at discharge rate of 0.1 C@250C (before reaching 80% capacity of its Initial Capacity).
- 5.2.3 The Batteries should have two-years Comprehensive replacement warranty.

### **5.3 OPzV / OPzS BATTERIES:**

- 5.3.1 Cycle life of the OPzV / OPzS battery (12V) must be minimum **2000** cycles @ 50% depth of discharge (DOD) at discharge rate of 0.1C@250C (before reaching 80% capacity of its Initial Capacity).
- 5.3.2 Cycle life of the OPzV / OPzS battery (2V Cell) must be minimum 2500 cycles @ 50% depth of discharge (DOD) at discharge rate of 0.1C@25°C (before reaching 80% capacity of its Initial Capacity).
- 5.3.3 The Batteries should have two-years Comprehensive replacement warranty.

### **5.4 LITHIUM BATTERIES (Life04):**

- 5.4.1 Cycle life of the Lithium LiFeP04 battery must be minimum 5750 cycles@50% depth of discharge (DOD) at discharge rate of 0.5C@25°C (before reaching 80% capacity of its Initial Capacity).
- 5.4.2 The battery shall comply with the requirements and recommendations outlined in IEC 62619:2022 issued by a recognized and accredited laboratory.
- 5.4.3 Lab test reports from a third-party laboratory verifying the claimed battery/cell cycle life shall be provided.
- 5.4.4 The LiFeP04 battery shall be covered by a comprehensive replacement warranty for a minimum of five (05) years.
- 5.4.5 The battery shall be equipped with an integrated Battery Management System (BMS) (Preferably active BMS) to ensure operational safety, reliability and communication with inverter or Charge Controller.
- 5.4.6 The BMS of the battery must have the following features but not limited to:
- Temperature protection
  - Over charge protection
  - Low voltage disconnects
  - High Voltage Disconnect
  - Short circuit alarm function
  - Self-balancing function
  - Over-current protection
  - Over-discharge protection
- 5.4.7 The LiFeP04 Battery must have LCD status and alarm indication.

- 5.4.8 The battery pack shall have a minimum ingress protection rating of IP30 or higher.
- 5.4.9 The charge and discharge rate shall be designed for 0.5 C minimum, but the battery must be capable of handling 1 C charge and discharge rates.
- 5.4.10 The battery shall be equipped with communication ports such as CAN/CAN/RS485/RS232 OR EQUIVALENT (one port for monitoring settings/data integration and one port for communication with inverter/Charge controller). Additionally, the BMS may have a wireless communication capability, such as Bluetooth, for monitoring, settings adjustment, and calibration purposes.
- 5.4.11 The above-mentioned specifications and details shall be clearly included in the data sheet, user manual, and all other relevant supporting documents submitted as part of the bid.

## **5.5 SUPER CAPACITOR BASED BATTERY BANK:**

- 5.5.1 Cycle life of the Super Capacitor based must be minimum 0.1 million cycles @ 100% depth of discharge (DOD) at discharge rate of IC@25°C (before reaching 80% capacity of its Initial Capacity).
- 5.5.2 The battery must have **an Active** Integrated Battery Management System (BMS) to ensure battery safety and reliability.
- 5.5.3 The Battery must have a Display LED for battery Voltage, Amperes etc. and should have alarm indications.
- 5.5.4 The charge and discharge rate of the battery must be designed at **IC minimum** and also capable of handling **continuously IC Charge** and discharge currents.
- 5.5.5 Warranty of battery for free repair & replacement should be minimum **Five years**.
- 5.5.6 Nominal Temperature for Super Capacitor battery shall be minimum -10 to +55 degree Celsius.
- 5.5.7 Super Capacitor battery shall be Non-flammable. (i.e.: Super Capacitor Cells should be non- petroleum based).

### **Note:**

- **Product brochure, Catalogue and certificates must be attached with the Technical Bid.**
- Battery Capacity test should be conducted by the contractor through accredited third-party laboratories within Pakistan

## **1. BOX / STAND FOR BATTERIES CHARGE CONTROLLER/INVERTER AND PROTECTION DEVICES:**

- a. The batteries should be housed in a vented compartment/stand that prevents users from coming in contact with battery terminals. This compartment/stand should be strong enough to accommodate the weight of the battery.
- b. A locking mechanism shall be provided to restrict unauthorized access to the battery compartment.
- c. The enclosure shall be manufactured from mild steel of at least 18 SWC thickness.
- d. The cabinet shall be hot-dip galvanized or powder-coated or Enamel Paint with Red Oxide, as mentioned in the BOQ.
- e. The entire enclosure/stand must be constructed to last at least twenty years without maintenance and should be protected against corrosion. The enclosure should have a clean and neat appearance. The entire enclosure/stand must have a neat, clean, and professional appearance, and the battery box/stand should be installed at a location suitable to the user's preference.
- f. The cabinet must be insulated with rubber corks covers at each cabinet leg to prevent direct contact with metal surfaces, ground, or other objects, or other objects, enhancing safety and stability.
- g. The cabinet shall have a designated area for mounting a user manual or instruction guide, along with the Site ID label.
- h. Provisions shall be made for the installation of protection devices such as fuses, breakers, and disconnect switches, as well as a clearly marked earthing point.
- i. All internal wiring shall be done in proper ducts and labeled for easy identification and maintenance.
- j. The cabinet shall include designated areas for labeling/stickering of all internal and external components for quick reference and identification.
- k. The cabinet shall incorporate sufficient ventilation slots or louvers to allow for natural airflow and heat dissipation, while protecting against dust and moisture.
- l. Cable glands shall be provided at appropriate locations to ensure secure and protected cable entry/exit.
- m. The design shall feature rounded corners or edge protectors to reduce injury risk during handling or maintenance.
- n. The cabinet shall have minimum Ingress protection of IP-21 or above.
- o. The cabinet may optionally support transparent panels to facilitate visual inspection and operational visibility.
- p. Pre-drilled mounting holes or brackets shall be available inside the cabinet for optional installation of circuit protection accessories.
- q. Clear and permanent safety signage such as polarity indicators, high voltage warnings, and earthing symbols on steel stamp shall be displayed on cabinet.

- r. Cabinets shall be properly wrapped and protected before shipment from the warehouse to the site to prevent any unnecessary damage during transportation and handling.
- s. The cabinet shall be installed with a minimum clearance of one foot above the finished floor level to ensure protection against moisture, dust, and other potential hazards.
- t. The Cabinet for modular installation should be in racks with proper insulation (preferably rubber insulation).

#### **6. (A) SOLAR CHARGE CONTROLLER (FOR SOLAR DC SYSTEM):**

- a. The controller shall support multiple battery types, including:
  - Flooded Lead-Acid (FLA)
  - GEL
  - Absorbent Glass Mat (AGM)
  - OPzV
  - OPzS
  - Lithium Iron Phosphate (LiFeP04)/Super Capacitor
- b. The charge controller shall be certified in compliance with international safety and performance standards, including but not limited to:
- c. The controller shall meet the following Ingress Protection (IP) ratings:
  - IP30 or higher for indoor installation
  - IP65 or higher for outdoor installation
- d. The controller shall utilize Single MPPT (Maximum Power Point Tracking) technology to optimize solar input performance.
- e. The MPPT tracking efficiency shall be  $\geq 99\%$ , and the overall energy conversion efficiency shall be  $\geq 95\%$ .
- f. The controller shall include automatic temperature compensation functionality to adjust charging parameters based on ambient temperature conditions, protecting battery health.
- g. The device shall provide comprehensive protection features, including but not limited to:
  - PV short-circuit protection
  - PV reverse polarity protection
  - PV over-voltage protection
  - PV over-current protection
  - Battery overcharging protection
  - Battery over-discharging protection
  - Battery reverse polarity protection
  - Load short-circuit protection
  - Overload protection
  - Reverse current flow protection from battery to PV modules
- h. The controller shall be equipped with an efficient thermal management system, including a properly dimensioned passive or active heat sink. to maintain safe operating temperatures.

- i. The charge controller shall include an CAN/RS485/RS232 OR EQUIVALENT communication port as standard. Support for additional communication protocols such as CAN, RS232, Wi-Fi, or Bluetooth shall be considered an added advantage.
- j. The controller shall be capable of operating in battery-less mode, delivering power to DC loads directly from PV modules where applicable.
- k. The controller shall be capable of communicating with LiFeP04 batteries via compatible communication interfaces. ensuring seamless integration with Battery Management Systems (BMS).
- l. The controller shall feature a digital interface. either integrated (LCD) or external, capable of displaying real-time operational parameters including:
  - PV voltage and current
  - Battery voltage and current
  - State of Charge (SOC) Preferred
  - Load status
  - Faults and alarms
- m. The controller may support data logging and remote monitoring features through compatible software or web-based platform.
- n. The controller shall support user-configurable charging algorithms or automatic detection for the connected battery type.
- o. Operating temperature range shall be 20°C to +60°C.°
- p. The charge controller should allow for wall, DIN-rail, or panel mounting, with proper size and clearly labeled wiring terminals. Mounting accessories should be included.

Note:- the efficiency test along with all protection features test may be conducted from the accredited laboratory in Pakistan.

**6. (B) All-in-One/Solar kit/Standalone Solar Systems must include the following features:**

- a. The all-in-one solar solution must include an MPPT charge controller (DC) or a hybrid inverter (AC), a LiFePO4 battery, and properly sized protection devices (breakers/fuses) for the PV modules, battery bank, and load connections, as per requirements and specifications in Section A (2). The type of solution—whether DC or AC—shall be specified in the BoQ.
- b. BMS (preferably active) communication between LiFePO4 Battery and MPPT Charge Controller/ Hybrid Inverter.
- c. Heat dissipation with proper heat sinks and cooling fans equipped with a fan controller must be available in case of IP-30 enclosure with proper heat sinks mechanism must be adopted.
- d. USB Mobile Charging Port must be available.
- e. The all-in-one must have individual ports for various load connectivity.
- f. DC All-in-One/Solar kit/Standalone-Solar Systems shall comply with relevant and applicable IEC standards (IEC 62257-9-5:2024) or latest.
- g. The All-in-one shall be equipped with communication port such as CAN/RS485/RS232 or equivalent for monitoring settings/data integration.

Additionally, the BMS may have a wireless communication capability, such as Bluetooth, or monitoring, settings adjustment, and calibration purposes.

- h. The All-in-one shall feature a digital interface, either integrated LCD/ LED, capable of displaying real – time operational parameters including:
  - PV voltage and current
  - Battery voltage and current
  - State of Charge (SOC)
  - Load status
  - Faults and alarms
  - Any other parameters as per Project requirement
- i. Wide PV voltage input range to support various panel configurations under IEC standards.
- j. The all-in-one enclosure shall be manufactured from mild steel of at least 16 SWG thickness for durability and rigidity.
- k. The all-in-one enclosure shall be hot-dip galvanized/ Powder-coated/ Enamel Paint with Red Oxide with technical parameters tag including Brand. Name, Product name, Model, Serial Number Manufacturing date, Input/ Output Power range, Input/ Output Voltage range, Input/ Output current range and Battery capacity.
- l. The enclosure must be insulated with rubber corks/ covers at each enclosure leg to prevent direct contact with metal surfaces. ground, or other objects, enhancing safety and stability.
- m. The all-in-one enclosure design Shall feature rounded corners or edge protectors to reduce injury risk during handling or maintenance.
- n. The all-in-one enclosure shall be properly packed and protected prior to shipment from the manufacturer's Warehouse to the site, to prevent any damage during transportation and handling.
- o. The requirements for LiFeP04s MPPT Charge Controller (DC) / Hybrid inverter (AC) detail are as under:
  1. **Battery (LiFcP04):**
    - a. Cycle life of the Lithium LiFeP04 battery must be minimum 5750 cycles @ 50% depth of discharge (DOD) at discharge rate of 0.5C@25°C (before reaching 80% capacity of its Initial Capacity).
    - b. Lab test reports from a third-party accredited laboratory verifying the claimed battery/cell cycle life shall be provided.
    - c. The maximum permissible self-discharge rate shall not exceed 5% of the rate capacity per month at 25°C.
    - d. The LiFeP04 battery shall be covered by a comprehensive replacement warranty for a minimum of five (05) years.
    - e. The battery shall be equipped with an integrated Battery Management system (BM) (Preferably active BMS) to ensure operational safety, reliability and communication with MPPT Charge Controller/On-Grid Hybrid solar system.

- f. The BMS of the LiFeP04 battery must have the following features but not limited to:
- Temperature protection
  - Over charge protection
  - Low voltage disconnects
  - High Voltage Disconnect
  - Short circuit alarm function
  - Self-balancing function
  - Over-current protection
  - Over-discharge protection
- g. The charge and discharge rate shall be designed for 0.5 C minimum, but the battery must capable of handling 1 C charge and discharge rates.

**2. In case of DC all-in-one/solar kit/standalone solar systems:**

- a. The controller shall be capable of communicating with LiFeP04 batteries via compatible communication interfaces, ensuring seamless integration with Battery Management Systems BMS.
- b. The controller shall utilize Single MPPT (Maximum Power Point tracking) technology to optimize solar input performance.
- c. The controller shall include automatic temperature compensation functionality to adjust charging parameters based on ambient temperature conditions, protecting battery health.
- d. The device shall provide comprehensive protection features, including but not limited to :
- PV over-voltage protection
  - PV over-current protection
  - Battery overcharging protection
  - Battery over-discharging protection
  - Battery reverse polarity protection
  - Short Circuit Protection for PV, battery bank and load connections
  - Overload protection
  - Reverse polarity protection for PV & battery bank connections.
  - Low voltage Disconnect (LVD) and Reconnect (LVR) to protect battery from deep discharge and allow safe reconnection.
- e. The controller shall be equipped with an efficient thermal management system, including a properly dimensioned passive or active heat sink, to maintain safe operating temperature.
- f. The controller shall be capable of operating in battery-less mode, delivering power to DC loads directly from PV modules where applicable.
- g. The controller shall support data logging and remote monitoring features through compatible software or web-based platforms.

- h. The controller shall support user-configurable charging algorithms or automatic detection for the connected battery type.
- i. The MPPT tracking efficiency shall be  $\geq 99\%$ , and the overall energy conversion efficiency shall be  $\geq 95\%$ .

**3. In case of AC all-in-one/solar kit solar systems:**

- a. The inverter shall be capable of communicating with LiFeP04 batteries via compatible communication interfaces, ensuring seamless integration with Battery Management Systems (BMS).
- b. Minimum 95% Conversion Efficiency at Rated Capacity (High Frequency Inverters).
- c. The Maximum power point tracking MPPT efficiency  $\geq 99\%$ . and converter efficiency  $\geq 92\%$ .
- d. The inverter should have built - in single MPPT controller.
- e. Hybrid Inverter (If quoted along with Lithium Batteries) may be capable of communication with the BMS of Lithium Batteries.
- f. Rated output voltage of inverter/ Controller shall be pure sine wave AC.
- g. Total harmonic distortion (THD) in AC output should not exceed 3% at rated capacity.
- h. Wide in put voltage range capability (i.e.: Voltage Range can be adjustable / selectable)
- i. The device shall provide comprehensive protection features, including but not limited to:
  - PV over-voltage protection
  - PV over-current protection
  - Battery overcharging protection
  - Battery over-discharging protection
  - Battery reverse polarity protection
  - Short Circuit Protection for P V, battery bank and load connections
  - Overload protection
  - Reverse polarity protection for PV & battery bank connections
  - Low Voltage Disconnect (LVD) and Reconnect (LVR) to protect battery from deep discharge and allow safe reconnection.

**6 (C) BRACKET FAN SPECIFICATIONS:**

- a. Fan Size: 14-16 inches
- b. Sweep Size: 350 mm
- c. Air Delivery: Minimum 75 m<sup>3</sup>/min
- d. Service Value: Minimum 1.65
- e. Operating Voltage: 230 V
- f. Frequency: 50 Hz
- g. Insulation Class: Class 155 (F-class) for safe and reliable operation
- h. Bracket Fan should be marked with the manufacturer name, model number, rated voltage & Wattage

**6. (D) AUTO VOLTAGE STABILIZER:**

- a. The stabilizer shall operate automatically and may be either block-based or servo- e (preferred the type and size of the stabilizer shall be specified in the Employer's Requirements).
- b. The winding material of the transformer core and all internal wiring shall have a minimum copper purity of 99.9%, with an allowable tolerance of  $\pm 0.1\%$  A copper purity test certificate from government-approved laboratory must be provided.
- c. A circuit breaker of appropriate rating (1.25 to 1.50 times of the input utility/gird current) shall be installed between the grid and the stabilizer for protection.
- d. The stabilizer should automatically cut off the power if the grid or utility input voltage is  $\geq 2270V$ .
- e. A three-pin plug and switch shall be installed on the output side of the stabilizer for operational convenience and safety.
- f. The stabilizer must be compatible with a frequency range of 50 Hz to ensure proper functioning in local gird conditions.
- g. The stabilizer shall maintain an efficiency of not less than 90% at any point when the input voltage is  $\geq 120V$ .
- h. At input voltage of  $\geq 120 V$ , the stabilizer must be capable of running at 50% of its rated capacity (in Watts)
- i. The stabilizer Shall be capable of providing a regulated output voltage in the range of 210V to 250V when the input Voltage is  $\geq 120V$ .
- j. The stabilizer must have digital voltmeter for both input and output measurement.
- k. The stabilizer must have the exhaust fan installed inside and shall have automatic temperature control through imbedded sensors.
- l. The block-based stabilizer must have relays capable of handling voltage fluctuations, ensuring fast response times to protect the load. and shall feature high-quality contacts, thermal resistance, and best coil insulation.
- m. The stabilizer may be equipped with LED indicators to display system faults and warnings for ease of monitoring and maintenance.

**Note: The copper purity test from any accredited laboratory of Pakistan.**

## **7. LED FLOOD LIGHTS:**

- a. Solar Based LEDs/Light fixtures shall conform to the latest IEC/ISO internationally recognized standards.
- b. LEDs/Light fixtures should not be Chip-on-board (COB) single chip due to their poor heat dissipation.
- c. LEDs/Light fixtures shall be modular type with proper heat sinks.

- d. Solar based lights (LED fixtures etc) should provide at least 120 Lumen/watt.
- e. The Colour rendering Index (CRI) must be equal or greater than 70
- f. LEDs/Light fixtures should be designed to deliver at least 10 years of service.
- g. Complete lightening unit shall be weatherproof (Protection Class IP67).
- h. The output from the LEDs/Light fixtures should be constant throughout the duty cycle.

**8. AC ENERGY EFFICIENT LED LIGHT BULBS:**

- a. Cap/Fitting/Base: E27
- b. Colour Temperature: Cool White
- c. Luminous Efficacy: Minimum 120 lumens per watt (L/W)
- d. Lamp Lifetime:  $\geq 2$  hours
- e. Power Factor:  $\geq 0.90$
- f. Rated Voltage: 220 - 230 Vac
- g. Rated Power: 14 to 18 Watts
- h. Must be NEECA certified.
- i. LED Light Bulbs should be marked with the manufacturer name, model number, rated voltage & Wattage as NEECA guidelines.

**9. AC ENERGY EFFICIENT LED LIGHT BULBS:**

- a. Must have rated Power: 45 to 55 Watts
- b. Sweep Size: 54" to 56"
- c. Rated Voltage: 220-230 vac ( $\pm 10\%$ )
- d. Service value ( $m^3/min/W$ ):  $\geq 4.5$
- e. Insulation Class:  $\geq 155$  (F-Class)
- f. Noise Level: Should be within acceptable comfort levels
- g.  $\pm 100\%$  variation in power consumption is allowed as per PSQCMNEECA standard
- h. Motor Core: Made of electrical steel sheet
- i. Winding Wire: 99.90/0 super enamelled copper CA wire or 99.9% pure copper wire
- j. The fan must be energy-efficient and clearly marked with the manufacturer's model number, rated voltage, and wattage as per NEECA guide line.
- k. Must be NEECA certified.

**10. DC ENERGY EFFICIENT LED LIGHT BULBS:**

- a. The LED lamps must have luminous efficacy of at least 100 Lumens/Watt.
- b. The LED lamp must be protected against reversed polarity of the operation voltage.
- c. Base shall be an E-27 thread type.
- d. The emitted light shall be cool or warm white.
- e. The wide angle shall be between 120 degree to 125 degree.
- f. Operating Voltage 12Vdc / 24Vdc.
- g. Lamps should be marked with the manufacturer model number, rated voltage, wattage and or batch number.

**11. DC CEILING FANS**

Sweep	Rated Power	Speed	Operating Voltage
Inches	Watts ( $\pm 10\%$ )	RPM	V
<b>48"-56"</b> (with speed control)	<b>18-60 (w)</b> BLDC	$\geq 320$ PRM	12 / 24 V

**12. DC PEDESTAL FANS**

Sweep	Rated Power	Speed	Operating Voltage
Inches	Watts ( $\pm 10\%$ )	RPM	V
$\geq 18"$ inch (with speed control)	<b>18-60 (w)</b>	$\geq 1250$ PRM (Full Speed)	12 / 24 V

**13. INVERTER BASED SPLIT AC**

Inverter based AC with both heating and cooling option.

S.No.	Description	Unit	Details
1.	Spilt AC	EER	$\geq 4$ star energy efficient
2.	Noise Level (Indoor)	DB (Max)	$\leq 50$
3.	Voltage Range	Volt (Min & Max)	180 to 270 Vac

**14. PVC CHANNEL DUCTS & PIPES**

- a. A product of good quality standard material from standardized firms/manufacturers with suitable size to be provided / used, as direction / approval of Engineer In-charge.
- b. Ducting must be done with proper steel nails/ screws and clips.
- c. The PVC duct shall be flame retardant.
- d. All ducting (wiring) must aligned.

**15. FLEXIBLE PVC PIPE**

- a. The flexible PVC should be of good quality material from standardized firm/manufacturers with suitable size should provided / used, as per direction / aval of Engineer In-charge.

**16. CIVIL WORK:**

The following Civil Works should be carried out for ground installation of SPV Modules/mounting structures.

- a. Minor Cutting and clearing of trees/plantation to avoid shadows.
- b. Civil work for earthing system as per the statutory requirements.

**17. REFLECTIVE / INSULATING PAINT**

The Roof Paint should be ultra-white, high reflective acrylic elastomeric roof sealer designed for fixing leaks in roofs the paint should contain heat reflective pigments and additives that provide an excellent. Highly protective barrier which reflects the sun's heat and destructive UV rays leaves a brilliant ultra-white finish, reducing surface heat absorption up 20°F.

The Reflective paint should comply with ASTM D6083, Fiber Reinforced for more protection, strength and durability which allows for contraction and expansion, Resists surface fungal growth.

**18. WARRANTY:**

Three years Comprehensive Free Replacement, Repair and maintenance Warranty at site (Free of Cost) should be provided for all the components of Solar System. (if not mentioned separately otherwise)

**18. (A) OPERATION AND MAINTENANCE MANUAL:**

An Operation and Maintenance Manual, in English / Urdu language, should be prepared and provided by the contractor with the solar PV System. The Manual should have information about solar energy, photovoltaic, Modules. DC/AC motor pump set, tracking system (if any), mounting structures, electronics and switches. It should also have clear instructions about mounting of PV module, DO's and DON T's and on regular maintenance and Trouble Shooting of the Solar System (Inverter etc.). Name and address of the person or Centre to be contacted in case of failure or complaint should also be provided.

**18. (B) STANDARDIZATION PRODUCTS:**

- a. Preference shall be given to standardized products approved by the C&W Department, provided they meet the minimum technical requirements outlined in the approved solar specifications.
- b. Only products from the Original Manufacturer shall be accepted. The contractor shall submit authentic brochures/data sheets and valid certifications clearly indicating the name of the original manufacturer.

**18. (C) EXCEPTIONS AND VARIATIONS:**

Any exceptions or variations to the specified requirements must be explicitly declared by the Engineer In- Charge in accordance with Section 27 of the Khyber Pakhtunkhwa Public Procurement Regulatory Authority (KPPRA) Act, as amended. The scope, justification, and rationale for each exception or variation shall be clearly documented and supported by relevant data.

**B Specification for Solar pumping System**

**19. PUMP SUBMERSIBLE:**

Pump should be supplied having standard ISO-9906 specifications. The pump must be submersible, made of stainless steel. The characteristic curves (Original from Manufacturer) showing the efficiency at duty point and performance of the pump should be provided in the technical proposal and also at the time of pre-supply testing. The quoted pump should be tested for its Performance and certified as per ISO-9906 standard. The pump should be suitable for installation and operation in tube wells/dug wells/open well with clear water discharge. Pump shall comprise of bowl assembly and non-return valve as integral part of pump's parts. Pump and motor shall rigidly couple through NEMA standard coupling. The stage casings of pumps should be connected as per NEMA/ANSI/AWWA /ASTM/BSS standard. Each stage casing must have replaceable wear ring. The impellers shall be secured to the pump shaft with tapered conical sleeves pressed into the taper bore of impeller or impeller secured through chrome plated stainless steel hexagonal sleeves. Suction casing must be between pump and motor with suction strainer as protection of pump against coarse impurities of the liquid handled.

**Specification for main components of the Pumps:**

S. No	Components	Specification
1.	Casing/Diffuser	The Casing/Diffuser should be in fabricated stainless steel AISI 304 /316.
2.	Impeller	Stainless steel AISI 304 / 316.
3.	Driving Shaft	Stainless steel 304/420 / 316
4.	Sleeves	Stainless steel AISI 329/ 304 / 316
5.	Gaskets	Rubber Gaskets
6.	Bearings	AISI 329 stainless steel
7.	Coupling & Screen + Cable Guard	Stainless steel AISI 316/3 19/304/420
8.	Non-Return Valve	As per British standard specifications (BSS),
9.	Pressure Gauge	N/A
10	Clamps	Steel - Pressed
11.	Pump Efficiency	Minimum efficiency of the pump (For discharge of more than 3000 iGPH) should be 70% ensured at duty point.

		(Duty Point of the Pump be preferably selected at the peak efficiency point or (Within $\pm 20\%$ of discharge) of Pump Peak efficiency Point)
--	--	--

**20. MOTOR:**

The winding material should be 99.99% copper. The motor should have wet type, water cool rewind- able/repairable stator. The motor should have non-disposable/ non-hermetically sealed winding / High Efficiency Water Cooled Rewindable Permanent Magnet Synchronous motors can be supplied for enhanced efficiency and other added advantages. The insulation class of the winding material should be mentioned. For each model quoted, all the technical parameters such as rated voltage, power factor, efficiency, full load ampere, speed and other similar parameters should be provided at the time of pre-supply testing. The testing report with all basic parameters should also be provided at the time of pre-supply testing. The motor shall be manufactured in compliance with National Electrical Manufacturer Association (NEMA) standards. The motor shall be three-phase submersible and shall be capable of operating at rated voltage of 380 - 415 Volts at 50 Hz - and 100 Hz in case of Permanent Magnet motor, (or as per VFD / Motor requirements). The motor should be capable of operating with variable speed through V/F control or Sensor less Vector Control. Winding of the motors shall of rewindable type with class - 1C40 insulation and 1P68 protection. The synchronous speed should be 2850-3000 RPM. Motor shall be capable of operating in well water with temperature normally start from 40°C. Motor should be designed for continuous operation. Motor must be filled with water without any chemical additive's hazards to health for cooling. The motor must be properly protected against the entry of well water sand etc by double mechanical seal one is rotating and other stationery and must be made of Silicon carbide/ Tungsten carbide and must be protected with sand protection guards. All supports shall be high grade cast iron and stator outer side jacket body should be in stainless steel in AISI 304. The excessive pressure due to heating up of the filled water must be compensated by a pressure equalizing rubber diaphragm in the lower part of the motor. The axial thrust of the pump shall be countered by oscillating sliding block type thrust bearing. The thrust bearing of the motor should be able to bear a downward thrust force from the water pump and the upward thrust force produced while starting the water pump. Motor in open well / water tank should be installed with cooling jacket / shroud / sleeve and when motor is installed in bore then installing of cooling jacket is also required.

**21. SUBMERSIBLE ELATE ELECTRIC CABLE (4-Core):**

The Submersible cable (4-Core) should be made of 99.9% copper strands with double PVC insulation for **1000Vac**, should adequately flexible and environment friendly. Standard and flexible insulated copper wires and cables must be used for all outdoor and indoor installation. The wiring that leads into the building shall be

protected in a conduit. The cable must have undergone quality tests as per BSS standards. Cable size should be selected so that the Voltage drop Losses in the drop cable should not be more than 2.5%.

Refer to Table-02 For Cable Sizing.

Following lab tests are mandatory.

- Conductor resistance test.
- Insulation resistance test.
- Pressure test.
- Spark test.

**Note:** The Supplier should provide the quality tests certificates at the time of pre-supply testing and inspection.

**22. COLUMN PIPE:**

The column pipe shall be flanged ERW steel pipes confirming to ASTM designation A-53 with a minimum thickness of **3.6 / 4.0 mm (3.6 mm for pipes up to 2.5" dia and 4 mm for pipes above 2.5")** and shall be painted with corrosion resistance paint of suitable thickness. Flanges thickness of 19-20 mm shall have grooves for cable passage. Each column pipe shall be complete with gaskets, bolts/studs, washers and nuts. All nuts, bolts. and washers shall be made of minimum A2 grade stainless steel.

The column pipe shall be supplied in interchangeable section having an approximate length of 10 feet column pipe shall be flanged perpendicular to the axis of pipe.

Column pipe size should be selected so that the Head Losses in the column pipe should not be more than 5%, HDPE Pipe 0.75 Inch diameter, SDR 13.6, PE 100, conforming to ASTM F-2160 Standard without Joints to be installed/included along with and equal to Column pipe for confirming Water Level testing purpose.

**FEATURES:**

- Manufacturer's pipes should meet international standards like BSEN 10255 & ASTM 53.
- Dimensional accuracy circularity and plan end cut should be observed,
- Weld strength of pipe and mechanical properties or raw material should be tested as per manufacturing standards.
- Pipes should be NDT tested (Non-destructive — Eddy current)
- Pipes should be hydrostatically pressure as per manufacturing standard.
- Pipes should be gone through straightening process to remove bendiness.

**TABLE-01: COLUMN PIPE SIZE WITH MAXIMUM DISCHARGE.**

Column Pipe Diameter (Inch/mm)	COLUMN PIPE DIMENSIONS (Minimum)	MAX DISCHARGE ALLOWED
--------------------------------	----------------------------------	-----------------------

25mm	PN12 / SDR 13.6 / PE100	1,300	286
32mm	PN12 / SDR 13.6 / PE100	2,300	506
40mm	PN12/ SDR 13.6/ PE100	4,650	1,023
50mm	PN12/ SDR 13.6 / PE100	8,250	1,815
2"	3.6 / 4 MM Thickness	12,000	2,640
2.5"	3.6 / 4 MM Thickness	21,000	4,619
3"	≥ MM Thickness	33,500	7,369
4"	≥ MM Thickness	70,000	15,398
5"	≥ MM Thickness	124,000	27,276
6"	≥ MM Thickness	200,000	43,994

**TOPSET:**

Top set shall comprise of Bore covers plate, (covering bore hole completely and securely), installation/suspension clamps (2-Nos). Sluice Valve (BSS/ASTM), Reflex Valve (BSS/ASTM), Washout Valve approx. 3-4 feet above the ground (T-Connection For Testing Pump's discharge), connector and cable jointing material (Cable connection from motor to switching device shall be joint free), Liquid Filled Pressure gauge minimum 4 Inch diameter suitable / appropriate for the required head pressure and cable ties. Bore Cover Plate should have provision for water level testing facility (i.e.: Hole for Sonic Water Level Meter / HDPE Pipe insertion).

- **Non-Return Valve / Sluice Valve**

As per British standard specifications (BSS), Minimum PN16 (16 Bar) or above (As Site Requirements). PN Value / Bar Capacity or Valves must be more than Installed Pump Max/Shut-off Head minus Static Water Level of Bore. (Leakages in Valves are NOT acceptable).

- **Pressure Gauge**

As per British standard specifications (BSS), having PSI or Bar scale (4 Inch Size), Liquid Filled, minimum 500 PSI Range or Above (As per Site Requirement), Siphon tube Pipe, Stainless Steel/polypropylene Casing.

For Cleaning of solar Panels, Plastic pressure pipe should be provided of suitable length to reach the furthest /last Solar Panel.

Every Water Supply Scheme should have a non-removable name plate fitted at suitable place / box having essential information and bearing the name of supplier, Consultant and client.

**24. SOLAR PUMP INVERTER / CONTROLLER:**

- a. The solar pump inverter/controller should have built-in advance version of Auto MPPT controller, overload protection, soft start/Soft Stop Features and Variable Frequency Drive (VFD) with integrated Gate Bipolar Transistors (IGBTs) of European, USA or Japanese origin or at least equivalent.
- b. The make and origin of the inverter/controller should be clearly mentioned in the catalogue and submitted in the technical proposal.
- c. The inverter offered should comply to or Equivalent standards:
  - i CE/RoHS
  - ii Low Voltage Directive 2014/35/EU
  - iii EMC Directive 2014/30/EU
  - iv IEC 62109-1 (Safety of Power Converters for use in PV Systems)
- d. The complete datasheet showing all the electrical parameters like input & output voltage ranges should be provided in the technical bid.
- e. All the electrical parameters like input & output voltage ranges, and efficiency should be provided at the time of pre-supply testing and inspection.
- f. Efficiency of inverter should be 96% and above at Rated Capacity.
- g. Efficiency of MPPT should be 98% and above.
- h. The inverter < 25kW ingress protection of inverter must be minimum IP 65 Rating or above and for inverter ≤25k W in ingress protection of inverter / enclosure will be minimum IP 54 Rating or above.
- i. Inverter / Controller having the capability to run both on AC and DC Power would be given preference.
- j. Inverter should have at least three (3) years product and performance warranty.
- k. The Pum Controller/inverter should have an ON/OFF Switch/Button to Start and Stop the Pump.
- l. Inverter should have active RS232/485 etc. communication port available, the Data available through this port can be used for Remote Monitoring.
- m. Inverter circuit must include protection against:
  - i Over or Low voltages and currents beyond critical level of the inverter's circuits.
  - ii Protection against accidental short circuits & reverse polarity connections.
  - iii Protection against lightning induced transients.
  - iv Over load protection.
  - v Low RPM Protection (i.e.: Frequency < 30 Hz or as per pump characteristic curve) Motor Should Stop.
  - vi Dry run protection. (PF / Current Based).

- n. In case of Permanent Magnet Motor. The inverter shall be capable of operating motors through V/F Control and sensor-less vector speed/ torque control; and shall have the feature of auto-learning necessary motor parameters.

**25. dV/dT or Sine Filters with Inverter (VFD):**

- a. The use of load reactors (dV/dT Filter) increases the reliability, performance and efficiency of VFD system, extend the life of both drives and motors, and reduces the amount of energy consumed by the motor / drive system.
- b. out dV/dT or sine filters (between VFD and Motor) for appropriate size (for 3 – Phase ≥ 380 Vac motor of class ≤ B insulation) should be use where the cable length between motor and inverter is more than Fifty (50) feet as advised/ recommended by the inverter manufacturer in their Technical Documentation. For cable lengths of more than 150 meters sine filter should be used.
- c. Filter should be enclosed in a vented box.
- d. Filter Efficiency should be minimum 97%.
- e. Filter should have a current rating of equal or greater than Motor FLA Rated Current.
- f. Distance between filter and pumping inverter should not be more than 2 meters.
- g. Motors with Installation Class F, H or above are exempted from the requirement of dV/dT Filter.

**26. SYSTEM DESIGN FOR PUMPING SYSTEM:**

- a. Suitable factor of safety should be applied while designing the system in order to have compensation for variations in irradiations.
- b. For Fixed Structure, the PV panel peak power at STC (Wp) should be 75% more than the Motor basic input power (PV Loss Compensation Factor = 1.75).
- c. For Auto / Manual Tracker, the PV panel peak power at STC (Wp) should be 50% more than the Motor basic input power (PV Loss Compensation Factor 1.5) or as per approval of Engineer In charge.
- d. If Single Axis Auto Tracker Structure is installed on the above factor, then daily operational timings of pumping can increased by 10-20%, as compared to fixed structure installation.

e. Total PV Power (Wp) (Imperial Gallons) = 
$$\frac{Q (iGPH*TDH (ft)*746 * PV Loss Factor}{60*3300 *n Pump *n motor}$$

f. Total PV Power (Wp) (US Gallons) = 
$$\frac{Q (US-GPHI *TDH (ft)*746*PV Loss Factor}{60*3960*n Pump *n Motor}$$

g. Total PV Power (Wp) (Metric Units) = 
$$\frac{Q m3/hr)*TDH (m)*9.81* *1000*PV Loss Factor}{3600*n Pump *n Motor}$$

- h. Voltage (V<sub>mp</sub>) of Each String of PV Panels should be as per details given below and String Voltage (V<sub>mp</sub>) should be within the MPPT range of Inverter.

- i For 380 V<sub>ac</sub> 3-Phase Motor = 380 \* 1.414 1.06 = 570 Vdc String, minimum

- ii For 220 Vac 3-Phase Motor = 220 \* 1.414 = 310 Vdc string.

- iii Small Inverters (i.e: 3-Phase, 220 Vac) with voltage boost function and DC Motors are exempted from the above voltage requirements. String can be made as per boost Inverter / Controller recommended String DC Voltage and should not be less than 240Vdc in any case.
- i. Details of each PV Panel string should be submitted in technical proposal (i.e: Nos of total strings and Nos of PV panels in each string along with wattage and  $V_{mp}$  of each PV panel).
- j. Unjustified Oversizing in PV Panels Wattage is not allowed.
- k. To avoid any oversizing, all commercially available PV Panels should be considered.
- l. Solar Pump Inverter should have a kW capacity equal or greater than the Motor Rated Input Power.
- m. Solar Pump Inverter / Controller Size (kW)  $\geq$  Motor Rated Power in KW/ Motor Efficiency.
- n. Solar Pump Inverter / Controller should have a current rating of 1.15 Times (minimum) Of Motor FLA Rated Current.
- o. Motor should not be loaded more than 90%. (i.e: Design / Calculated BHP should not be more than 90% of Motor Rated Horse Power)
- p. Along with this specification, contractors should also satisfy manufacturer's recommendations for all major components of Solar Pumping System.
- q. Requirement of Efficiency for Motor i.e. 75% will not apply on Motors smaller than or equal to 5.5HP and the requirement of efficiency for pump i.e. 70% will not apply on pumps having discharge equal to or lower than 3000 GPH.

#### **27. PRESSURE PUMPS (UP TO 5.5111'):**

- a. Submersible pump conforming to ISO-9906 Standard.
- b. Pump + AC Motor (3-Phase-220V/380V) or DC Motor and Pump with Display Unit.
- c. Solar pump inverter/controller should be MPPT based and Minimum Ingress Protection of IP65.
- d. In case, where the column pipe diameter is less than or equal to 50 mm (For discharge equal or less than 8250 LPH and/or for Motor 5.5 HP and below), HDPE pipe of at least PN12 / SDR 13.6 / PE100 (For TDH of equal or less than 300 ft) without joint may be used instead of MS pipe for better economics and to avoid hydraulic losses. However stainless-steel rope of minimum diameter of 6 mm (28 mm<sup>2</sup>) for suspension of pump-set must be supplied with HDPE pipe. (Note: For TDH of more than 300 ft, HDPE Pipe type / thickness may be increased/changed accordingly)
- e. Top set shall comprise of Suitable Galvanized stand (Design should be verified from Engineer In-Charge before start of work)
- f. deleted

- g. Connection to overhead water storage tank. Top bend, S.S Fasteners & Erection clamps.
- h. Civil work to protect borehole i/e foundation.
- i. The pump should operate safely with Sand particles up to (50) gram/m<sup>3</sup>

#### **28. DC SOLAR WATER PUMP-SETS P TO 5.5 HP**

- a. DC Motor can also be provided for Equal or less than 5.5 HP.
- b. Motor should be capable of both AC and DC operation. There must be auto power source recognition feature.
- c. The motor should be brushless (BLDC), permanent magnet type.
- d. The Controller must have a display Unit, showing all essential parameters (i.e.: Current, Voltage etc.).
- e. The Controller must of MPPT type. MPPT efficiency should be equal or more than 98%
- f. Pump should have auto and soft start / stop feature.
- g. The um set should have following protections.
  - 1. Dry Running Protection
  - 2. Reverse Polarity Protection
  - 3. Over phase protection
  - 4. Over Head Protection
  - 5. Lose Phase Protection
  - 6. Electronic Protection
  - 7. Over Current/ Overload Protection

#### **29. SOLAR AUTO TRACKER:**

- a. The solar tracker offered should be fully automatic and intelligent and must be capable of Single axis tracking (from east to West) and should have its own power supply (PV Panel, Battery and Charge Controllers) other than PV Panel used for Pumping Setup.
- b. Individual Auto-Tracker should be  $\geq 6$  kW each and Tracking Accuracy should be within  $\pm 50^\circ$
- c. The auto Tracker should also have manual control mode to adjust the tracking angle manually. All Structure Material Should be Hot Dipped Galvanized Steel Minimum 80 Microns).
- d. The auto Tracker should also have manual control mode to adjust the tracking angle manually. All Structure Material Should be Hot Dipped Galvanized Steel (Minimum 80 Microns) or epoxy coating with red oxide (as per direction of Engineer incharge).
- e. All nuts, bolts, washers and other fasteners for mounting structure shall be made of minimum A2 grade stainless steel.
- f. Foundation and other details will be separately provided.

- g. Three years Comprehensive Free Replacement, Repair and maintenance Warranty (Free of Cost) should be provided for all the components of auto Tracker (including Batteries).

**30. PV MOUNTING FRAME WITH MANUAL TRACKING:**

- a. Suitable for Up to 6.5 KW PV Panels easily movable in multi directions having flanges with bearing balls 7/16" and having angle adjustment.
- b. Base steel cage 7/8", MS rod 3.5 feet length with nut-bolts system for strong anchoring.
- c. Pillar pipe 5 mm with 6" dia, base plate 15 "x 15" x 16 mm size with 04 numbers of supports.
- d. Support for PV, 4mm thickness 5" dia pipe and side plates.
- e. MS I Beam/Garder side bracing C Channel frame 3"x7"x 1/8". C Channel frame 3" x1 1/2" x 1/8" for panel mounting
- f. Steel structures/frames shall be enamelled paint with lead oxide.
- g. Galvanized nuts, bolts and washers for tracker fitting.
- h. Steel frame shall be properly designed and shall withstand wind speed/load of at least 130km/hr and tough weather condition.

**31. PRE-SUPPLY TESTING & INSPECTION:**

The firm applying for the tender has to provide the recent test bed reports from the pump/motor manufacturer or any other third party as per ISO-9906 standard. Each of the offered pump set models must undergo these tests prior to supply and installation, in order to ensure the quality and standard of the equipment contractor may be asked to provide test result conducted by third party for re-verification.

**32. (Deleted As repetition of Section A, serial 18 (A))**

**C SPECIFICATION FOR SOLAR HOMES & BUILDING SYSTEM****33. GRID TIE INVERTER (ON-GRID WITHOUT BATTERY BACKUP / HYBRID WITH BATTERY BACKUP)**

1. UL-1741 Certified or IEC 62109-1 and IEC 62109-2 or Equivalent Certificates.
2. Minimum 95% Conversion Efficiency at Rated Capacity (High Frequency Inverters).
3. Minimum 87% Efficiency for Transformer based inverters (Low frequency Inverters).
4. The inverter should have built-in MPPT controller.
5. The Priority of the inverter should be set that load will be running from the solar energy then Grid and, in the end, will be running from the Battery Backup.
6. Inverter (Hybrid Only) must be capable of configuring for Charging GEL, Lead Carbon, OPzV/OPzS Batteries and Lithium Iron Phosphate batteries (LiFeP04).
7. Hybrid Inverter (If quoted along with Lithium Batteries) may be capable of communication with the BMS of Lithium Batteries.
8. Rated output voltage of inverter / Controller shall be pure sine wave AC.
9. Total harmonic distortion (THD) in AC output should not exceed 3% at rated capacity.
10. The degree of protection of the inverter Installation should be IP-65 or above.
11. Wide input voltage range capability. (i.e.: Voltage Range can be adjustable / selectable)
12. Natural convection cooling for maximum reliability
13. Outdoor enclosure for unrestricted use under any environmental conditions
14. Capability to connect external sensors for monitoring environmental conditions.
15. The output of the inverter must synchronize automatically its AC output to the exact AC voltage and frequency of the grid.
16. The Inverter should have the capability of Parallel operation up to three units. (Only For projects, where more than one inverter should be installed).
17. Inverter should have active CAN/RS485/RS232 or equivalent etc. communication port, the Data available through this port can be used for Remote Monitoring.
18. Liquid crystal display should at least be provided on the inverters front panel or on separate data logging/display device to display following.
  1. DC Input Voltage
  2. DC Input current
  3. AC Power output (k W)
  4. Current time and date
  5. Temperatures (C)

## 6. Converter status

19. Inverter circuit must include protection against:

- Over or Low voltages and currents beyond critical level of the inverter's circuits.
- Protection against accidental short circuits.
- Protection against lightning induced transients.
- Over load protection.

20. The Maximum power point tracking MPPT efficiency  $\geq 99\%$  and converter efficiency upto 98% of MPPT charge controller.

21. The inverter shall be equipped with certified anti-islanding protection in compliance with international standards (e.g., IEEE 1547, IEC 62116), to ensure immediate disconnection from the grid during outages or abnormal grid conditions.

### **34. OFF-GRID / HYBRID INVERTER:**

1. The Inverter must be pure sine wave output suitable for 220 Volt, 50 Hz.
2. Inverter must be capable of configuring for Charging GEL, Lead Carbon, OPzV/OPzS Batteries and Lithium Iron Phosphate batteries (LiFeP04) (If Applicable).
3. The Inverter / system must have a MPPT Solar charge Controller.
4. Minimum 92% Conversion Efficiency at Rated Capacity (High Frequency Inverters).
5. Minimum 87% Efficiency for Transformer based inverters (Low frequency Inverters).
6. Total harmonic distortion (THD) in AC output should not exceed 3% at rated capacity.
7. The inverter must be user programmable for selecting P V, Grid and Battery Priority as well as Built-in programmed and user defined voltage and current settings of the charge controller for GEL, Lead Carbon, OPzV/OPzS batteries and Lithium Iron Phosphate batteries (LiFeP04).
8. The Inverter must have Protective function limits for:
  - a. AC under voltage protection
  - b. AC over voltage protection
  - c. Battery under voltage Alarm
  - d. Low Voltage Disconnect
  - e. High Voltage Disconnect
  - f. Overload and Short Circuit Protection
  - g. Over Temperature Protection
9. The inverter must be ISO 9001, ISO 14001 and CE Certified.
10. The inverter must have IEC 62109-0 1 and IEC 62109-2, or Equivalent Certificates.
11. The degree of protection of the inverter Installation should be IP-65 or above.

- 
12. Wide input voltage range operation capability. (i.e.: at least 170 V to 270V for Operation)
  13. Inverter should have active CAN/RS485/RS232 or equivalent etc. communication port, the Data available through this port can be used for Remote Monitoring.
  14. Inverter (If quoted along with Lithium Batteries) must be capable of communication with the BMS of Lithium Batteries.
  15. Inverter settings be preferably password protected.
  16. Inverter should be capable of battery less operation (preferred or as per BOQ requirement).
  17. Discharge Current should be preferably programmable (i.e.: discharge battery Current can be limited to user desired values).
  18. The Maximum power point tracking MPPT efficiency 2 99%, and converter efficiency up to 96% of MPPT charge controller.

**Note:**

The THD (Total Harmonic Distortion), inverter capacity and efficiency may be conducted from the accredited laboratory in Pakistan.

**D SPECIFICATION FOR SOLAR STREETS LIGHTS****35. SOLAR STREET / ROAD LIGHT SYSTEM DESIGN:**

- a. The assessment Of Wattage of the LED Luminaire, Pole Height, Pole thickness, Pole top diameter, Pole base diameter. Base plate size, Base Plate thickness, Stiffener size, Stiffener thickness, Pole arm design, Pole Arm Length, Pole arm thickness, Pole arm diameter, Pole arm Placement / Fixing position, RCC foundation size, Anchor / J-bolt size, Steel Rebars cage (Mesh) and Number of Poles (Pole to Pole distances), should according to the design provided / approved by the Engineer In-charge.
- b. Round Conical or Octagonal Hot Dipped Galvanized Pole of average 80 Microns should be installed.
- c. All Nuts, Bolts and Washers should be stainless steel.
- d. pole base plate should be tightened in between two stainless steel nuts and washers (one nut and washer at upper and one nut and washer at lower side of the base plate).
- e. All Anchor / J-bolt shall be in level and align to each other.
- f. All Anchor / I-bolt shall be galvanized.
- g. All Anchor / J-bolt shall have at least 150 mm minimum threads.
- h. All poles shall be installed on levelling nuts secured to the anchor bolts and with locking nuts on the top of the base flange.
- i. The concrete ratio should be 1 :2:4 for RCC foundation.
- j. proper sketches of Pole, base plate, RCC Foundation and Steel Rebars cage (Mesh) should be provided and approved from Engineer In-charge.
- k. In order to focus on winter sun availability and Easy cleaning of Solar panel from dust etc with Rain water, Solar Panels should be installed at 1800 Azimuth Angle, and the Tilt angle (slope) of PV Module should be between  $45^{\circ} \pm 5^{\circ}$  (Only for Solar Street Lights).

**36. LED SOLAR ROAD/STREET LIGHT FIXTURE:**

1. LED Efficacy must be greater than or equal to 130 Lumens/Watt.
2. The fixture must be IP-66 Rated or above.
3. The Colour temperature of the LED should be Pure white in the range of 5000-6000 K.
4. The LED Light distribution must be IESNA Type-II
5. The LED must be suitable for working Temperature from  $-40 \sim + 60^{\circ}\text{C}$  with relative humidity of 15% ~90%
6. The Colour rendering Index (CRI) must be equal or greater than 70.
7. The LED Light Fixture must be LM79 and LM80 Tested.
8. LEDs/Light fixtures should not be Chip-on-board (COB) single chip type due to their poor heat dissipation.
9. LEDs/Light fixtures shall be modular type with proper heat sinks.
10. The output from the LEDs/Light fixtures should be constant throughout the duty cycle
11. LED Life should be greater or equal to than 50,000 Hours.

12. The LED Light Fixture must have the following certification:

- ISO 9001
- ISO14001
- CE (EMC and LVD) Certified or equivalent.
- International standard Certifications

Note: Product Brochure, Catalogue and certificates must be attached with the Technical Bid

### **37. SOLAR CHARGE CONTROLLER FOR STREET / ROAD LIGHT**

- a. The charge controller must be suitable for the required battery voltage, auto voltage recognition feature and capable of charging flooded, GEL, AGM, OPzV, OPzS, & Lithium ferrous phosphate (Life PO4) Batteries.
- b. The charge controller must be IP-67 rated or above for outdoor installation.
- c. The charge controller must be Remote Controlled for parameter setting. The system must have the following feature:
  - Remote Parameter Setting and Monitoring
  - Remote control of the Lights (on/off, timer setting etc.)
- d. The charge controller must have MPPT Technology and Automatic Battery Voltage Recognition.
- e. The charge controller must have at-least three stage Flexible dimming function (0-1000/0).
- f. The Maximum power point tracking MPPT efficiency  $\geq 99.0\%$ , and converter efficiency up to 98%.
- g. It must have temperature compensation for charging batteries in higher temperatures.
- h. Charge controller must have the following protections:
  - PV Short circuit
  - PV reverse polarity
  - PV over voltage
  - PV over current
  - Battery over charging
  - Battery over discharging
  - Battery reverse polarity protection
  - Load short circuit
  - Load overload protections
- i. It must have proper heat sink to dissipate excessive heat
- j. The charge controller must have protection for reverse flow of current through the PV modules
- k. Controller should have active port for GSM based communication for Remote Monitoring.
- l. Mid Night based timing controller will be preferred.
- m. The Solar Charge controller must have the following certification:
  - ISO 9001
  - CE Certified

**Note:** Product Brochure, Catalogue and certificates must be attached with the Technical Bid

**38. Battery and Controller Box:**

- a. The battery box should be made of Hot Dipped Galvanized Sheet of average 80 Microns.
- b. Stand deleted.
- c. For Pole Mounted batteries Battery must be made of minimum 16 SWG sheet and must have proper locking arrangement for protection against theft.
- d. For underground battery installation, the battery box should be made of minimum 16 SWG sheet and should be properly sealed to ensure protection against water. Proper cable glands and packing material should be used to ensure water proofing of the box.
- e. The battery and Controller Box should be at least IP65 ingress protection.

**39. (Deleted As of Section A (2))**



### Appendix – II Earthing Grounding Drawings

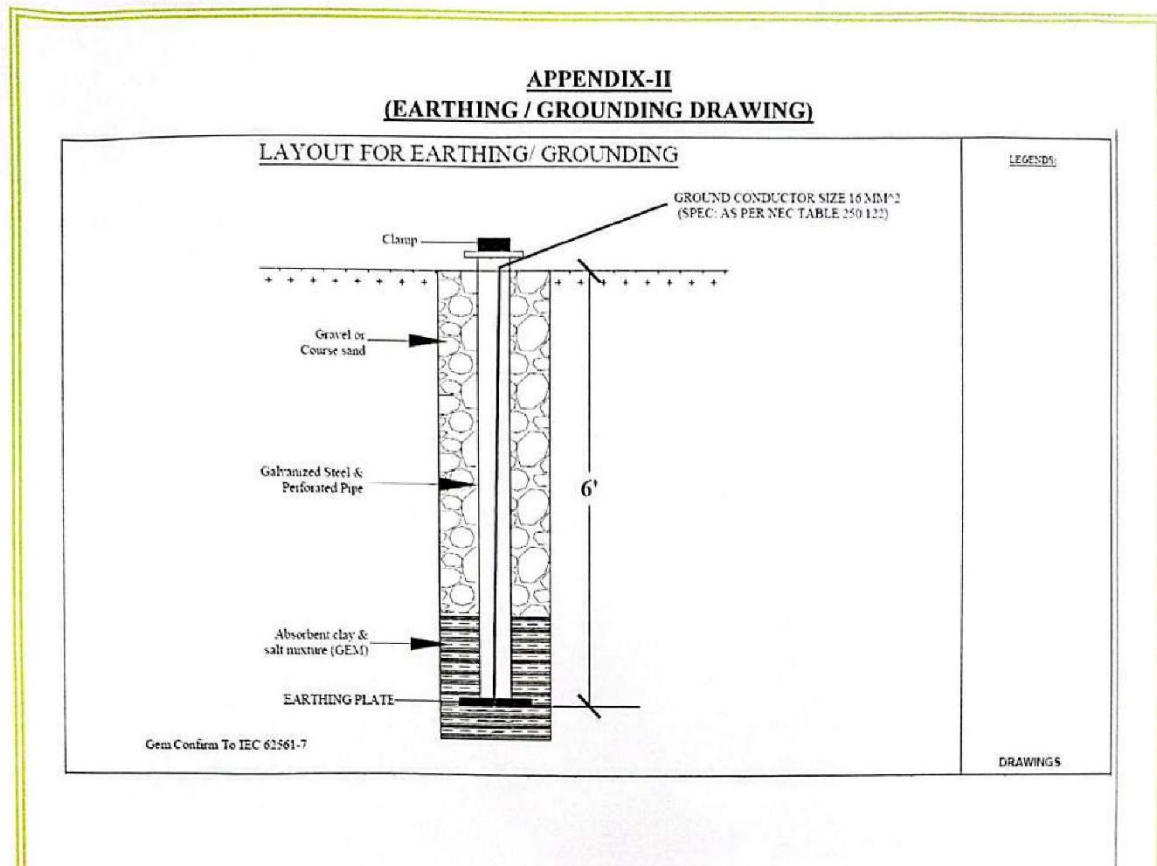

### APPENDIX-III TOPSET LAYOUT:

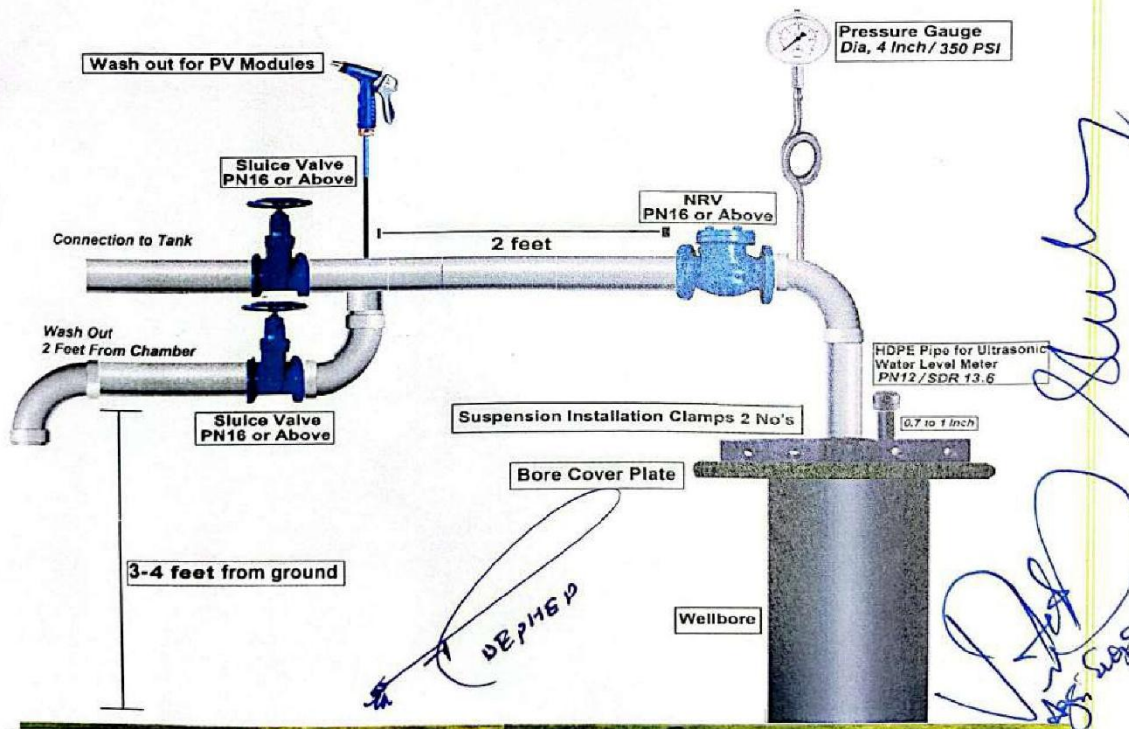

Appendix – IV (SYSTEM SINGLE LINE DIAGRAM-PUMPING)

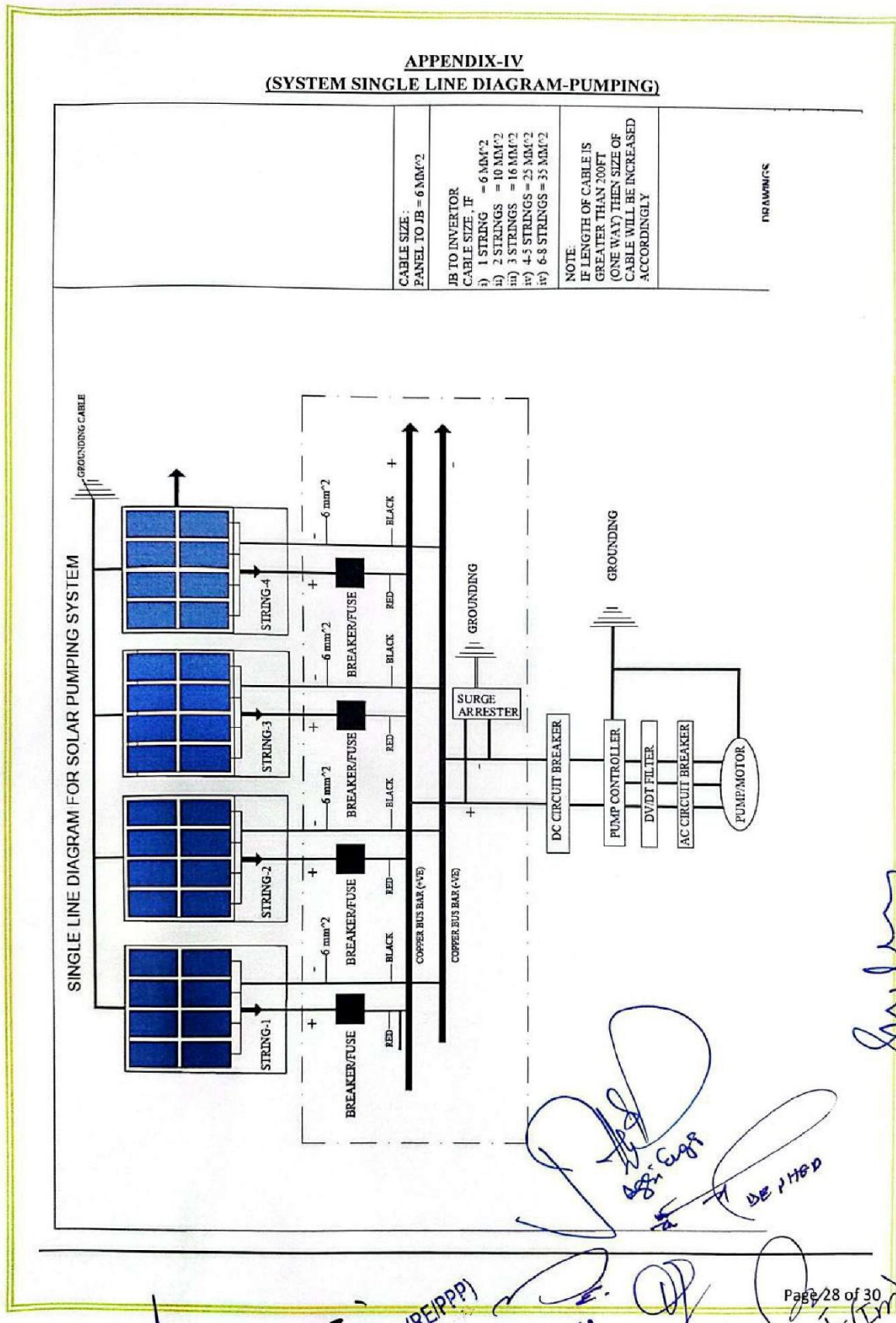

**Appendix – V (JUNCTION/COMBINER BOX SCHEMATICS DIAGRAM)**

**APPENDIX-V  
(JUNCTION/COMBINER BOX SCHEMATICS DIAGRAM)**

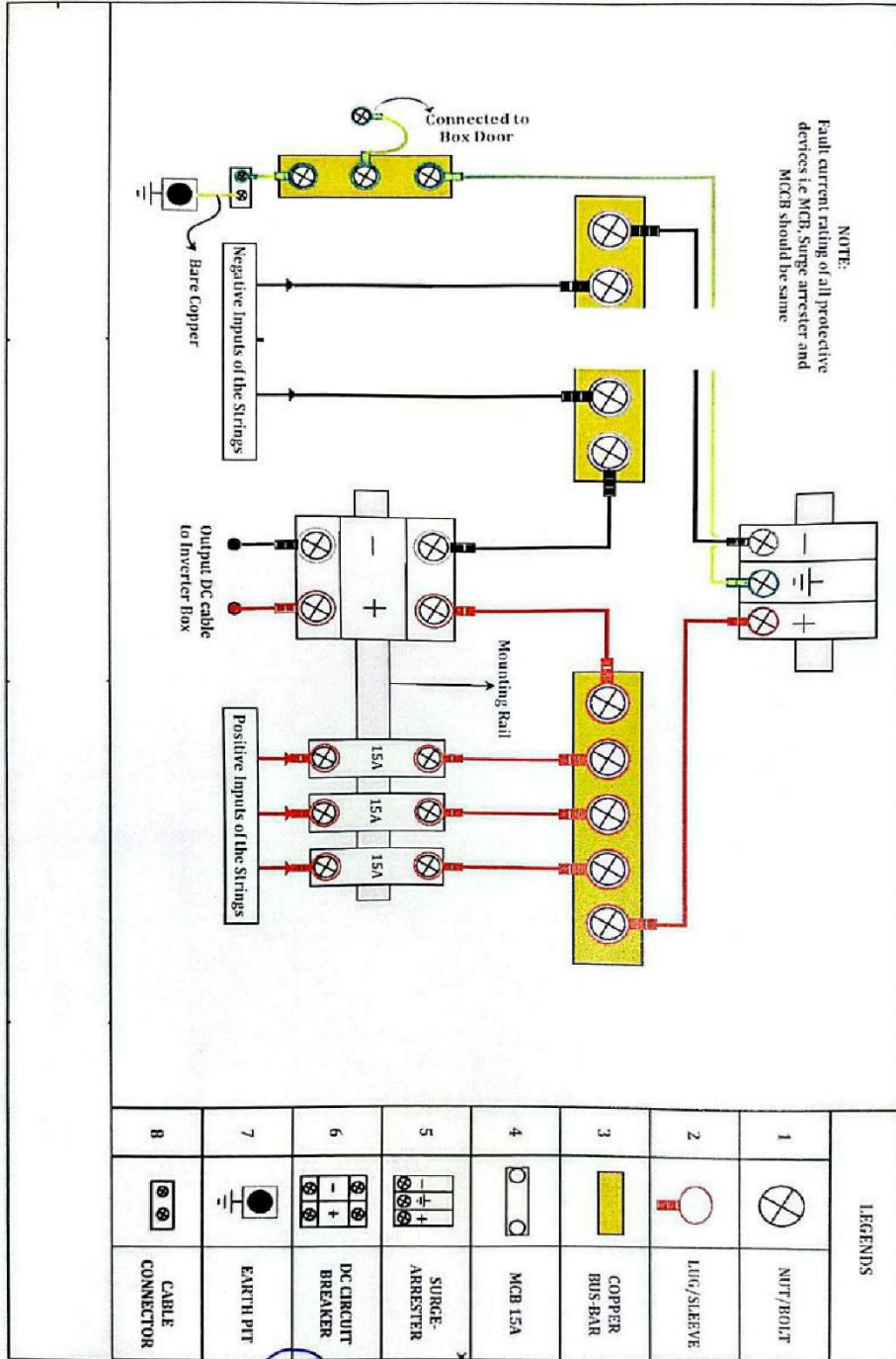

NOTE:  
Fault current rating of all protective devices i.e MCB, Surge arrester and MCCB should be same

*Handwritten signature*

*Handwritten signatures and notes:*  
 DEPTEN  
 Page 29 of 38  
 Engineer (RE/PPP)  
 CCDA

Appendix – VI

**MINIMUM SIZE OF BOUNDING/EQUIPMENT GROUNDING/GROUNDING ELECTRODE CONDUCTORS AND GROUND BUS**

**Table 250.122 Minimum Size Equipment Grounding Conductors for Grounding Raceway and Equipment**

Rating or Setting of Automatic Overcurrent Device in Circuit Ahead of Equipment, Conduit, etc., Not Exceeding (Amperes)	Copper	Aluminium or Copper-Clad Aluminium
15	14	12
20	12	10
30	10	8
40	10	8
60	10	8
100	8	6
200	6	4
300	4	2
400	3	1
500	2	1/0
600	1	2/0
800	1/0	3/0
1000	2/0	4/0
1200	3/0	250
1600	4/0	350
2000	250	400
2500	350	600
3000	400	600
4000	500	800
5000	700	1200
6000	800	1200
<b>Size (AWG or kcmil)</b>		